

Rinnai

Installation and User Manual

REU-VR2632FFUD - 26i

REU-VR2632WDHD-E - HD50e

REU-VR2632FFUDHD-E - HD50i

REU-VRM3237WHD-E - HD70e

REU-VRM3237FFUHD-E - HD70i

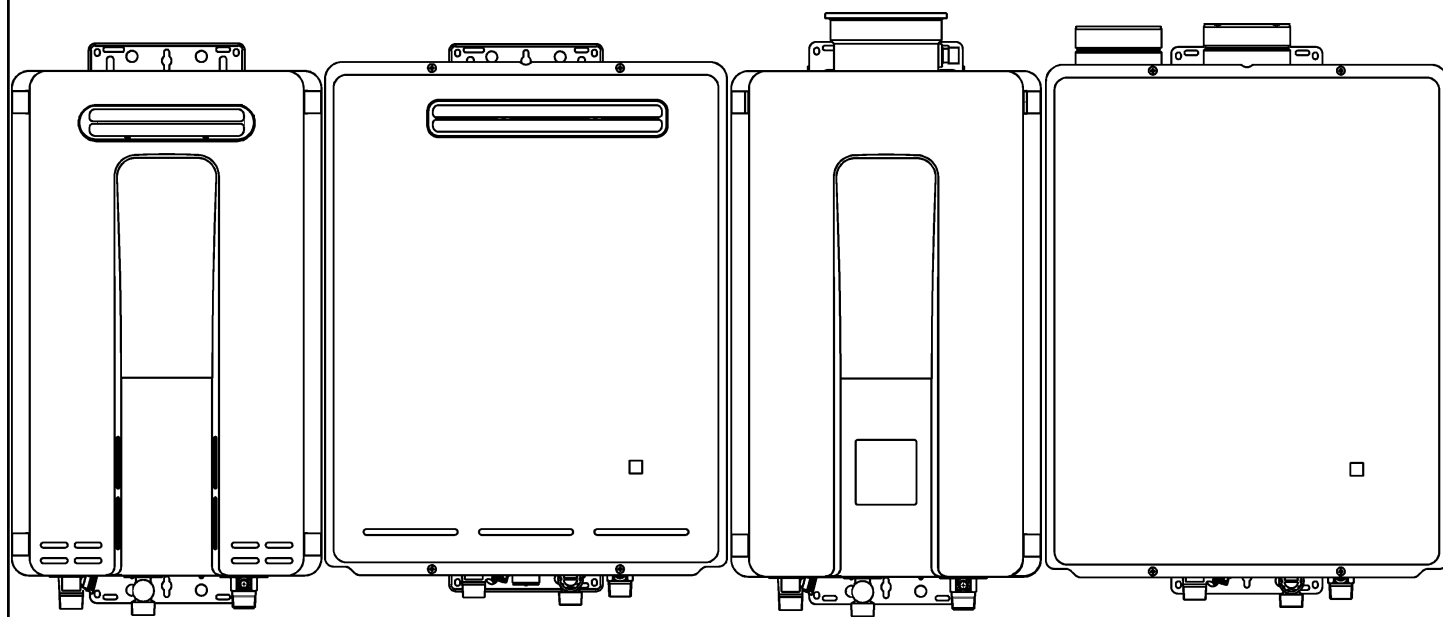

Continuous Flow Water Heater

Important.

Read these instructions carefully before attempting installation or use of this appliance.

All work must be carried out by competent persons.

The Rinnai range of water heaters, when correctly installed, comply with the requirements of the United Kingdom Water Regulations / Byelaws (Scotland). These Products can be found listed in the Water Fittings and Materials Directory.



The Rinnai water heaters are CE Marked as allowed by Technigas



26i - REU-VR2632FFUD-E

HD50e - REU-VR2632WDHD-E

HD50i - REU-VR2632FFUDHD-E

HD70e - REU-VRM3237WHD-E

HD70i - REU-VRM3237FFUHD-E

*Certificate numbers: E0841/5386 Rev.5 - E0716/5360 Rev.05
E1061/5498 Rev.1 - E1060/5498 Rev.1*

ID number: 0461BP0795 - 0461BO0739 - 0461BS0903 - 0461BS0903

Date of Issue: 23/12/2004 - 28/07/2003 - 26/10/2007 - 26/10/2007

Quality System Standard

ISO 9001 - 2008

The Design, Development, and Manufacture of Gas Water Heating Appliances done under Rinnai's Quality Management System is certified under the Quality Management System Standard ISO 9001.

Registration Number JQ0003D
Registered since: February 1994
Certified by JIA—QA Centre.

CONTENTS

CONTENTS	3
USERS INSTRUCTIONS	4
FEATURES AND BENEFITS	5
IMPORTANT INFORMATION	6
OPERATION WITHOUT REMOTES	8
STATUS MONITOR	8
TEMPERATURE CONTROLS	9
ERROR MESSAGES	14
RESTARTING THE RINNAI WATER HEATER	15
UK CARING AND MAINTENANCE	16
INSTALLATION INSTRUCTIONS	17
UK INSTALLATION INSTRUCTIONS	18
UNPACKING RINNAI WATER HEATER	19
OPERATION	19
MAIN COMPONENTS	22
INSTALLATION INSTRUCTIONS	23
UK INSTALLATION INSTRUCTIONS	25
FLUE REQUIREMENTS	26
UK FLUE REQUIREMENTS	29
TEMPERATURE CONTROLS	30
EZ CONNECT	32
TESTING	33
GAS PRESSURE SETTING	34
DIP SWITCH SETTING	36
DIMENSIONS	38
TECHNICAL DETAILS	42
FLOW CHART	44
WIRING DIAGRAM	45
DIAGNOSTIC POINTS	47
WATER FLOW CHARACTERISTICS	48
LETTER OF COMPLIANCE	49
CE CERTIFICATE	50
COMMISSIONING CHECK LIST	54
COMMISSIONING SHEET	55
SERVICE RECORD	56
UK WARRANTY	57
PRODUCT FICHE	59
CONTACT	61
HEATER DETAILS	61

USERS INSTRUCTIONS

The following instructions are designed for the user of the water heater. The user may not install or adjust the appliance in any way that requires the removal of the front cover of the unit. To remove the front cover of the unit you must be certified competent to do so. Information for the Installer is given on **page 17**.

All work done on this appliance must be done by a qualified gas engineer. A qualified gas engineer must carry an up to date GAS SAFE Registered Gas Installer photo identification card while working on gas appliances. If you are unsure do not be afraid to ask the engineer to show you the card. If you are still not satisfied call GAS SAFE on 0800 408 5500 and verify the engineer's name with their database. This is for your own safety.

Responsibilities of the USER

The user must abide by all warnings given in this book. The user must only reference the user section of the book, and may not carry out any procedure listed in the installer section. This installation manual should be kept with the appliance for maintenance and user information.

The user must have the unit checked and maintained annually by a gas engineer.

The user must periodically check the water filter on the inlet to the appliance.

The user must not use the appliance in any way that it was not meant to be used. The user may only use the heater as detailed in the User portion of this manual.

Interference with a sealed component is not permitted. In case of defect parts only use genuine Rinnai components for replacement.

Conversion to other gas types should only be carried out by a qualified installer or a gas distributor according to the practice in the country where the unit is installed.

The user must not store or use any flammable vapours or liquids in the vicinity of this or any other appliance.

The user should familiarise themselves with the water heaters gas service valve and the main gas valve to the premises.

ATTENTION: air surrounding the water heater, venting and vent termination(s) is used for combustion and must be free of any compounds that cause corrosion of internal components. These include corrosive compounds that are found in aerosol sprays, detergents, bleaches, cleaning solvents, oil based paints/ varnishes, and refrigerants. Therefore Rinnai recommends outdoor models be used for these locations where possible. The water heater, venting and vent termination(s) should not be installed in any areas where the air may contain these corrosive compounds. If it is necessary for a water heater to be located in areas which may contain corrosive compounds, Rinnai strongly recommends the following:

Indoor/Internal Water Heaters:

- * DO NOT install in areas where contaminated air is present
- * Consider before installation where air has the ability to travel within the building
- * Where possible, install the water heater in a sealed closet so that it is free of contaminated indoor air
- * Chemicals that are corrosive in nature should not be stored or used near the water heater

Outdoor/External Water Heaters and Vent Terminations of Indoor/Internal Water Heaters:

- * Install as far away as possible from exhaust vent hoods
 - * Install as far away as possible from air inlet vents. Corrosive fumes may be released through these vents when air is not being brought in through them.
 - * Chemicals that are corrosive in nature should not be stored or used near the water heater or vent termination.
- Damage and repair due to corrosive compounds in the air is not covered by warranty.

The exhaust outlet may change colour over time due to the condensate in the exhaust gases. This discoloration does not damage the part or its form, fit or function.



Benchmark places responsibilities on both manufacturers and installers. The purpose is to ensure that customers are provided with the correct equipment for their needs, that it is installed, commissioned and serviced in accordance with the manufacturer's instructions by competent persons and that it meets the requirements of the appropriate Building Regulations. The Benchmark Checklist can be used to demonstrate compliance with Building Regulations

and should be provided to the customer for future reference. Installers are required to carry out installation, commissioning and servicing work in accordance with the Benchmark Code of Practice which is available from the Heating and Hotwater Industry Council who manage and promote the Scheme. Visit www.centralheating.co.uk for more information.

IF YOU SMELL GAS

Isolate the gas supply and get out of the building. Do not try to light any appliance. Do not turn any light or other electrical switch on or off. Do not use any telephone in the building. Call your gas engineer from a safe location and follow their instructions. If you cannot reach your gas engineer ring the following: National Grid 0800 111 999

FEATURES AND BENEFITS

Congratulations on purchasing the technologically advanced, temperature controlled, Rinnai Hot Water System.

- Rinnai water heaters will NEVER RUN OUT of hot water. As long as electricity, water, and gas supplies are connected, hot water is available when hot water taps are open.
- Built into the main micro-processor is the facility to LIMIT THE MAXIMUM TEMPERATURE of the hot water supplied. The water temperature may be set to various temperatures. This is particularly useful when the hot water unit is installed where young children or the infirm may be using the hot water. If required, the temperature can be changed via the dip switches on the PCB or with a localised controller. For further information, please contact Rinnai.
- Rinnai water heaters are powered flue appliances. This makes them COMPACT, saving both floor and wall space.
- The temperature of outgoing hot water is CONSTANTLY MONITORED by a BUILT-IN SENSOR. If the temperature of the outgoing hot water rises to more than 3°C above the selected temperature the burner is shut OFF and only turned ON again when the temperature falls to below the selected temperature.
- The burner lights automatically when the hot water tap is opened, and extinguishes when the tap is closed. IGNITION IS ELECTRONIC, so there is no pilot light. When the hot water tap is off, no gas is used.
- The Rinnai *32 litres models* water heaters have a built in Status Monitor on the front of the unit to display error codes and run condition.
- Up to four external temperature controllers can be mounted remotely from the heater. One Standard control is supplied with all appliances (except for HD range). The remote offers the following additional features:
 - Localised temperature setting
 - Diagnostic information
 - Error Codes
- 'Deluxe' Temperature Controllers are an optional extra. These provide functions including Bath Fill, Voice Prompt, and Clock Setting.
- Temperatures selected at the controllers are retained in the SYSTEM MEMORY.
- Operating NOISE LEVEL IS VERY LOW.
- ERROR MESSAGES ARE DISPLAYED on the Temperature Controllers and Status Monitor, assisting with service.
- FROST PROTECTION device built in as standard.

IMPORTANT INFORMATION



Excessively hot water is dangerous, especially for young children and the infirm. The water heater allows you to control the temperature of your hot water to safe levels.

Water temperature over 50°C can cause severe burns instantly or even death from scalding.

Children, disabled and the elderly are at the highest risk of being scalded by excessively hot water.

Always test the temperature of the water before bathing or showering.

Burns from hot water taps can result in very severe injuries to young children.

Hot water at 65°C can severely burn a child in less than half a second. At 50°C it takes five minutes.

Burns can occur when children are exposed directly to hot water or when they are placed into a bath which is too hot.

DO

Do stay with children whenever they are in the bathroom.

Do take them out of the bathroom if you need to answer the phone or door.

Do test the temperature of the water with your elbow before placing your child in the bath.

Do make sure that the tap is turned off tightly.

Do consider setting your Rinnai Water Heater at a maximum temperature of 50°C.

Do install a child proof tap cover OR,

Do install a child resistant tap.

DO NOT

Do not leave a toddler in the care of another small child. The older child may not have safely set the temperature.

- **Consider child-resistant taps or inexpensive tap covers**, both of which prevent a child's hand from turning on the tap.
- **Consider reducing the temperature of the water supplied to the hot tap to 50°C.**
- This approach can be extremely valuable because it requires a one time action for a long term reduction in risks of scalds. This type of automatic protection is important during times when a parent or carer has been distracted.

IMPORTANT INFORMATION

Always check water temperature before use.

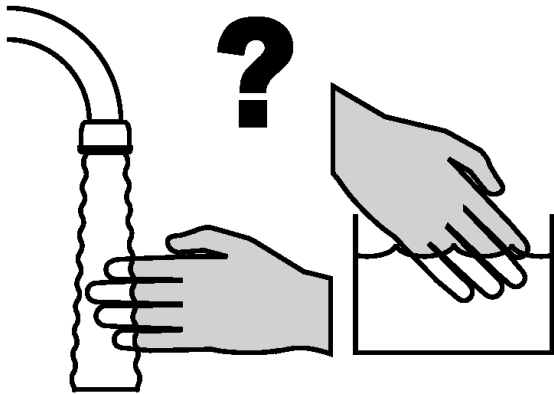

Refer to warning about hot water on **page 6** for important safety information.

Hot water may go cold without warning at very low water flows (less than 3 l/min).

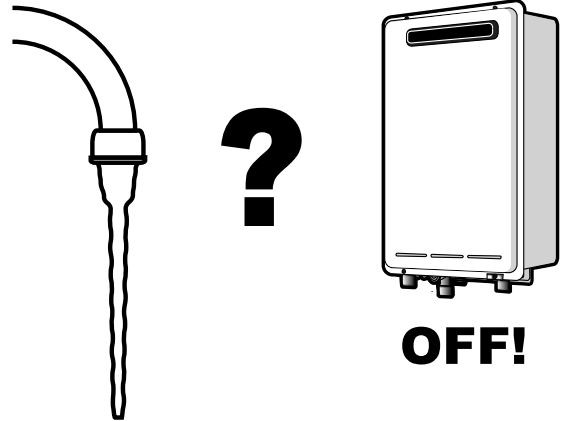

The delivered water temperature is controlled automatically. The water from the hot tap may be reduced after the temperature shown on the remote control is raised. The water flow may also vary with the temperature of the incoming water supply.

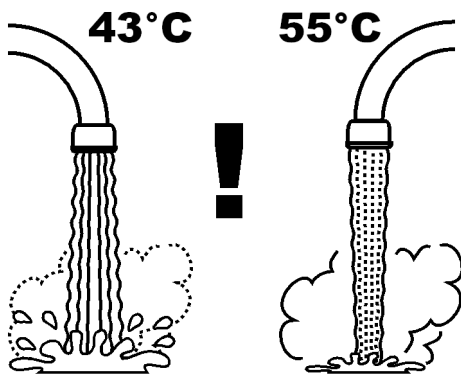

If freezing temperatures are expected, turn off the water and gas, and drain the water heater.

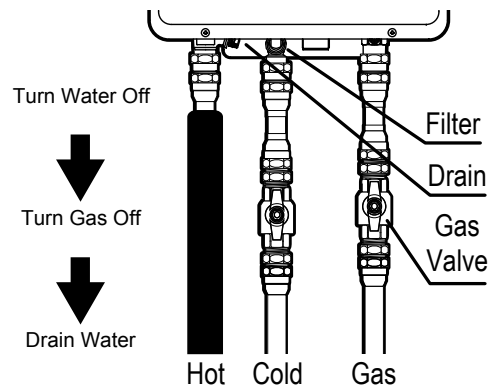

If the power is left on the Automatic Frost Protection will prevent the unit from Freezing. Frost protection is standard on all units.

Keep flammable materials, trees, shrubs, chemicals, etc. away from the flue outlet / terminal.

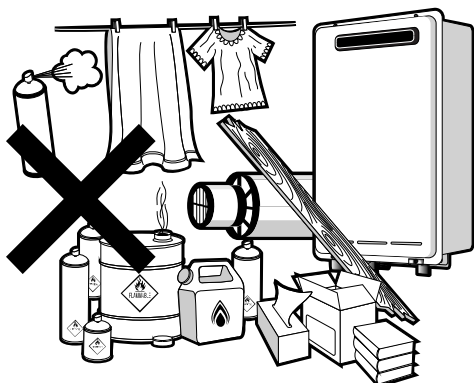

Do not spray water into flue terminal

Do not touch the flue outlet. Do not insert objects into the flue outlet / terminal.

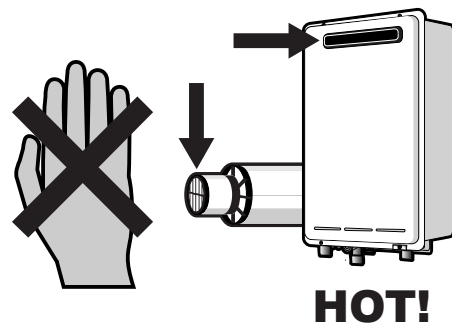

On cold days steam may be discharged from the flue outlet. This is normal, do not be alarmed. It does not indicate a fault.

OPERATION WITHOUT REMOTES

Rinnai products have no pilot light and operate automatically as soon as water flow is sensed. The burner ignites with electronic ignition and the flame extinguishes as soon as water flowing through the appliance stops.

Turn On by opening the hot water tap

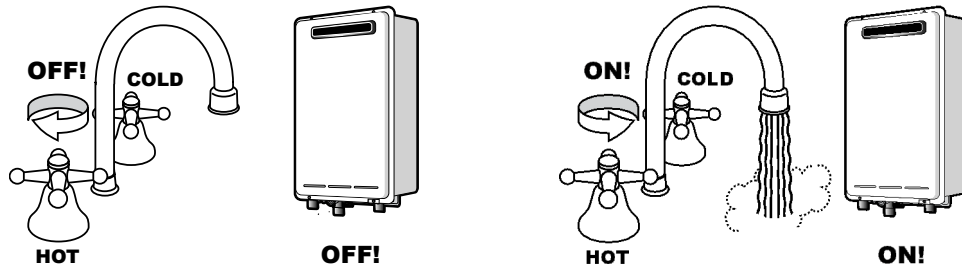

The Rinnai range of water heaters are factory preset to a temperature of 55°C (HD range to 65°C). Other limits, lower or higher, are available on request. Temperature controllers are available to allow precise digital temperature control. Controllers can be installed at any time after installation of the hot water unit.



Excessively hot water is dangerous. Rinnai water heaters allow you to control the temperature of your hot water to a safe level.

Water temperatures above 50°C can cause severe burns instantly, such scalding may even result in death. Those most at risk are children, disabled, elderly and the infirm. Hot water at 65°C (a very common water temperature in the UK) can severely burn a child in less than half a second. At 50°C it takes five minutes. Consider using Thermostatic Mixing Valves on the Hot Water Outlets.

STATUS MONITOR

The Rinnai 32 litres water heaters have a built in status monitor on the front.

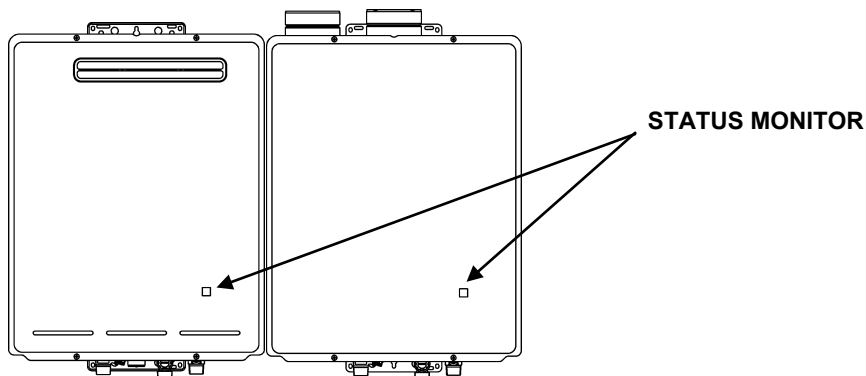

The status monitor has three conditions:

1. The water heater is off (no water flowing): the monitor is blank.
2. The water heater is on (heating water): the monitor displays the set temperature.
3. The water heater should be on, but is not (water is flowing, heater is not on): the monitor will display a flashing error code.

TEMPERATURE CONTROLS

The purpose of a Temperature Controller is to enable the user to have localised control over the hot water supply.

Used correctly, the hot water unit will supply hot water at the temperature selected, even when the water flow is varied, or when more than one tap is used.

Adjustments to the operation of your hot water unit can be made with any of the Temperature Controllers.

Each Temperature Controller can be individually programmed.

Up to four universal can be fitted with Rinnai water heaters. Universal Controllers allow temperature selection only and one comes as standard with the water heater.

Deluxe Temperature Controllers are available as an optional extra.

These controllers have temperature selection, bath fill, voice prompt, and time clock functions.

When more than one universal Controller is used one may be set as the Master Controller to allow temperatures above 50°C.

(ask Rinnai for more information)

Various water temperatures (°C) can be selected as follows:

Universal Controller:

37, 38, 39, 40, 41, 42, 43, 44, 45, 46, 48, 50°C

Master universal Controller:

37, 38, 39, 40, 41, 42, 43, 44, 45, 46, 48, 50, 55°C (60, 65°C HD)

Deluxe Bathroom Controller:

Hot Water Delivery: 37, 38, 39, 40, 41, 42, 43, 44, 45, 46, 48, 50°C

Bath fill Delivery: 37, 38, 39, 40, 41, 42, 43, 44, 45, 46, 47, 48°C

Deluxe Kitchen Controller:

37, 38, 39, 40, 41, 42, 43, 44, 45, 46, 48, 50, 55°C (60, 65°C HD)

If a temperature of 43°C or higher is selected on any controller and this temperature is then decreased to below 43°C and increased again whilst the water is running, the maximum selectable temperature will be 43°C. This provides additional safety for the user.

Suggested temperatures are:

Kitchen 50°C - 65°C**; Shower 39°C - 43°C; Bath fill 39°C - 45°C

*** This temperature may not be available on all installations.*

These temperatures are suggested starting points for selection. You may find higher or lower temperatures are more comfortable. Maintaining lower temperatures helps to save energy. To obtain water temperatures lower than 37°C simply add cold water.

When multiple temperature controllers are used they allow the temperature to be set from various locations by pushing the transfer button which gives that controller priority over the system. The temperature selected by the controller with priority will be available to all outlets.

TEMPERATURE CONTROLS

Remote temperature controllers provide control over the water temperature. Rinnai water heaters can be operated with 1, 2, 3, 4 or no temperature controllers.

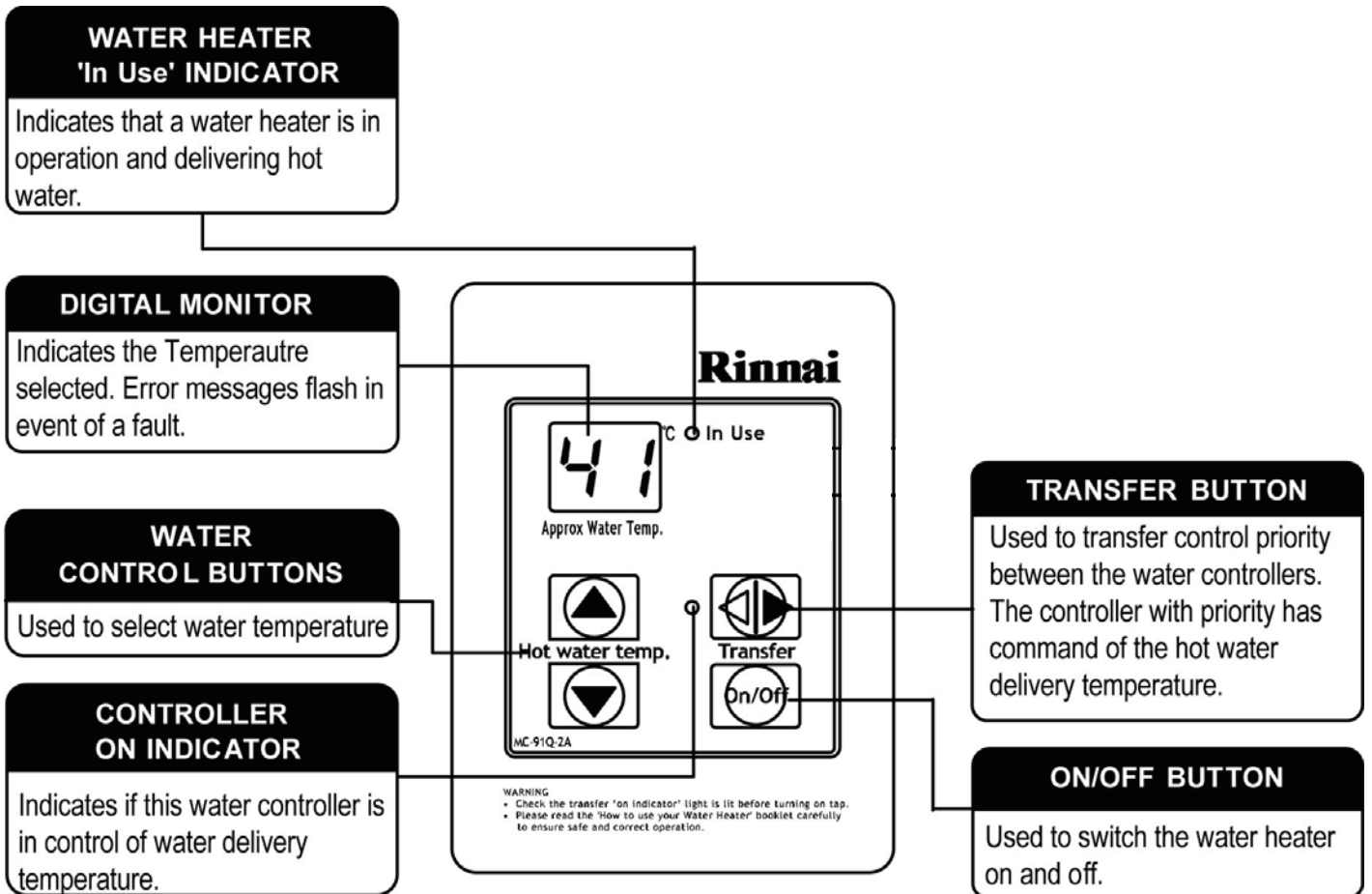

NOTE Each time a button is pressed, a BEEP will sound. The BEEP sound can be muted by depressing the Temperature Controller Up and Down buttons simultaneously for more than 3 seconds. This can be done for each Temperature Controller. To return to original settings, repeat this step.

Safety features

Whilst the hot water tap is open, the following safety features apply:

- Temperature selection cannot be transferred.
- The temperature setpoint on the controller with priority can always be lowered, but the setpoint can only be raised to 43°C.
- Other controllers are unable to take priority or change the delivery temperature of the water.
- If off, the controller cannot be turned on.



NOTE The temperature of the outgoing water is constantly monitored by a built in sensor.

If the temperature of the outgoing hot water rises to more than 3°C above the selected temperature shown on the digital display, or the preset limit if controllers are not fitted, the burner will automatically go out.

The red operation indicator will also go out.

The burner will ignite again once the outgoing hot water temperature falls to that shown on the digital display (or the pre-set limit of the Rinnai heater).

TEMPERATURE CONTROLS

Using the Temperature Controllers

Press the **ON/OFF** button on a temperature controller after making sure that water is not flowing.

The system will become active, the temperature will default to 40°C and the controller that turned the system on will have priority.

The temperature setting on the controller will light up.

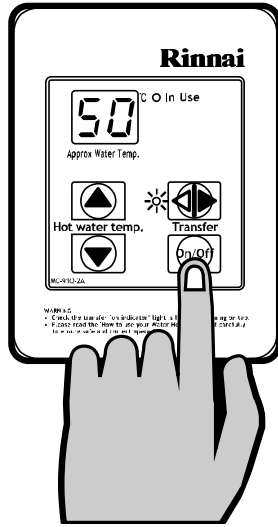

Adjusting Temperature

Simply press the Hot Water Temperature Up or Down arrow button

HOTTER

COOLER

until the desired temperature is displayed on the digital display.

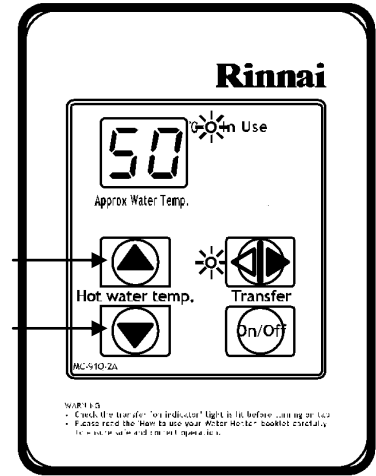

Using Hot Water

To operate the heater, simply turn any hot water tap on. This will automatically light the burner providing hot water. The red **IN USE** indicator will glow on the temperature controller.

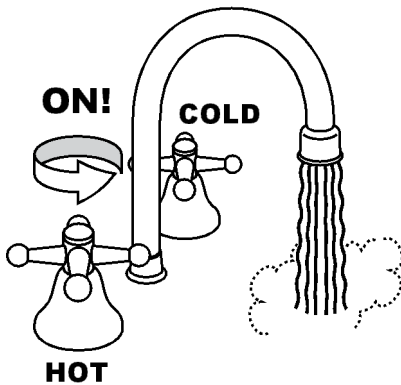

To turn off your hot water system

During normal operation the system is left on.

To turn the system off simply press the **ON/OFF** button on any temperature controller (where fitted). This will shut the water heater down completely including the temperature controller digital display.

The Digital Monitor will go out.

If hot water taps are opened when the Rinnai is off, cold water will flow from the taps.

If the system is to be left off over the winter be sure to drain it down if there is a possibility of freezing temperatures.

Using High Temperature Display Controllers

You will need to program the Master controller if you want to display and use temperatures over 50°C. Programming only needs to be done on Master universal controller; other universal controllers will not allow this. Deluxe Kitchen controllers are supplied already programmed to allow high temperatures.

STEP 1: On the Master controller only press and hold the **Transfer** and **ON/OFF** buttons simultaneously (see Fig. 1) until a “beep” is heard (approx. 5 seconds).

STEP 2: When the Primary controller is switched on it should be possible to select temperatures higher than 50°C. If not repeat STEP 1.

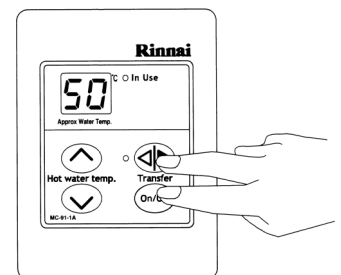

Fig. 1



NOTE

If the master controller is replaced, repeat STEP 1 above for the new controller.

TEMPERATURE CONTROLS

Using 2 or more universal Temperature Controllers.

Switching the system ON.

The hot water system and all controllers can be switched ON and OFF from any controller by pressing the **ON/OFF** button as shown. When the system is turned ON the water temperature display will be lit.

During normal operation the system is left ON. Do not push the **ON/OFF** button when water is running.

Using hot water.

Ensure the system is switched **On** by verifying the temperature display is lit. Ensure the local controller has priority by verifying the **Transfer** LED indicator is lit. If it is not then press the **Transfer** button once. This gives the local controller priority of temperature over the system.

Select the desired temperature using the **Hot water temp.** buttons. The selected temperature will be displayed on all controller displays. This is the water temperature which will be supplied from the heater.

Bathroom temperatures should be no more than 50°C.

Open the hot water tap. The appliance will be activated and the **In Use** indicator will be lit.

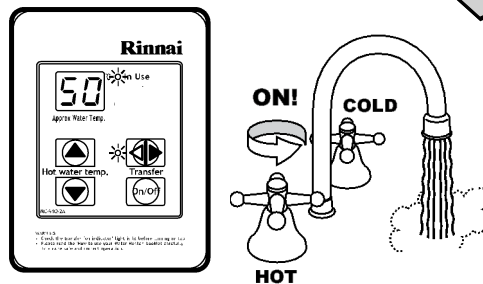
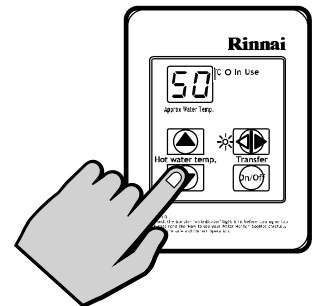
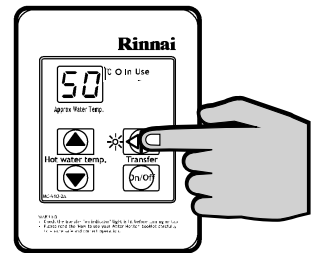
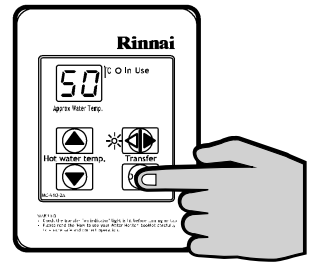

Using 4 Universal Temperature Controllers.

You will need to activate the fourth controller.

STEP 1: On the Master controller press and hold the **Transfer** and **ON/OFF** buttons simultaneously (see Fig. 2) until a “beep” is heard (approx. 5 seconds).

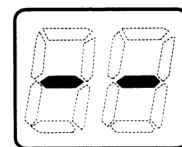

Fig. 1

STEP 2: Check that the display on all Four controllers is lit and displaying a temperature when switched on. If any ONE of the controllers displays two dashes (see Fig. 1) in the display repeat STEP 1.

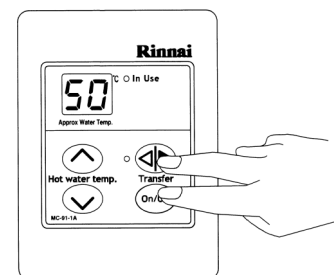

Fig. 2



NOTE If the master controller is replaced, repeat STEP 1 above for the new controller.

TEMPERATURE CONTROLS

Do not push the ON/OFF button on the Master controller after transferring priority of temperature selection to a Secondary controller as the system will shut down.

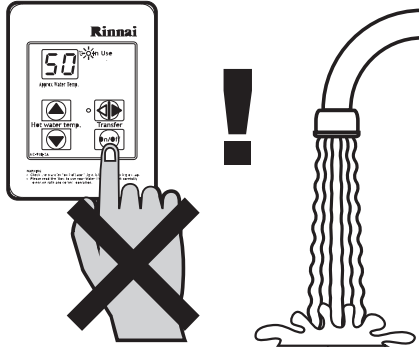

Do Not Turn OFF the Master Controller

Temperature priority cannot be switched to another controller when the water is flowing through the water heater.

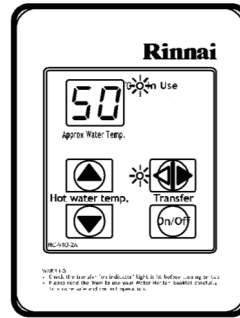

Controller 1
in use

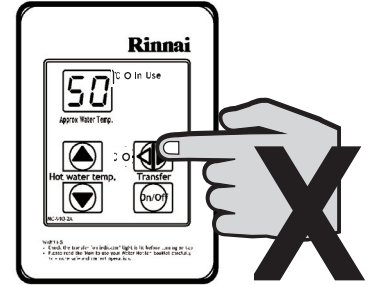

Controller 2
cannot take
priority

If a temperature over 50°C has been selected on a controller and priority of temperature selection is transferred to another controller, then back again, the temperature on the controller will automatically drop to 50°C.

If the set point is 50°C or less it will not alter.

This is a safety feature.

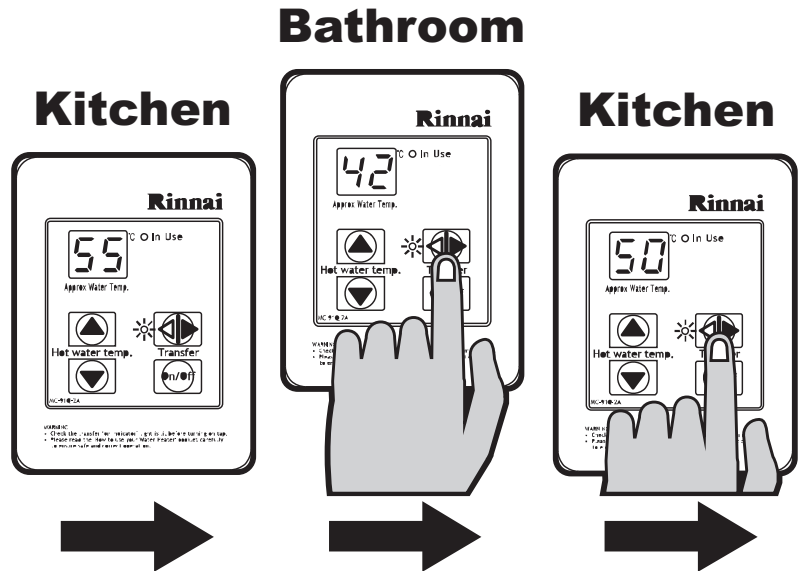

Depending on the weather conditions and the length of the pipe between the heater and the tap in use, there may be a variation between the temperature displayed at the controller and the temperature at the tap.

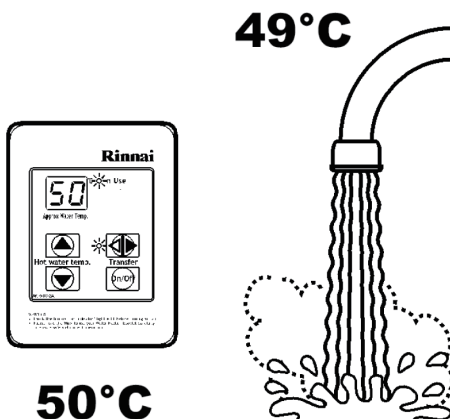

Do not clean the control with solvents or detergents. Use only a soft damp cloth.

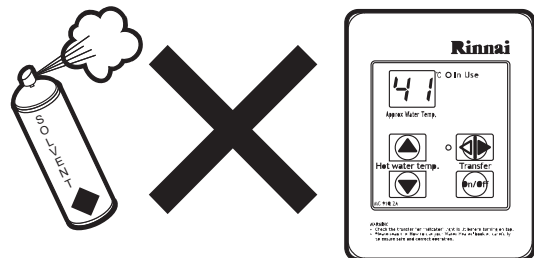

ERROR MESSAGES

Rinnai water heaters have the ability to check their own operation continuously. If a fault occurs, an error code will flash on the digital display (and on the Status Monitor) if you have temperature controllers installed. This assists with diagnosing the fault, and may enable you to overcome a problem without a service call. Please quote the code displayed when enquiring about service.

Code Displayed	Fault	Remedy
-	Noticeable reduction in water flow	Inlet water filter needs to be cleaned.
03	Power interruption during operation (water will not flow when power returned)	Turn off all hot water taps and circulating pumps. Press 'On/Off' twice
10	Not enough combustion air	Check for physical blockages around air intake or exhaust. Check combustion fan.
11	No Ignition / Gas supply	Check gas valves, gas supply and sparker unit.
12	Flame failure / Earth Leakage	Check gas valves and gas supply. Check flame rod. Check earth wire lead. Check remote control.
14	High flame safety device	Service Call
16	Over temperature warning	Service Call
32	Outgoing water temperature sensor faulty	Service Call
33	Heat exchanger outlet sensor faulty	Service Call
34	Combustion Air Temperature Sensor faulty	Service Call
52	Gas modulating valve faulty	Service Call
61	Combustion fan failure	Service Call
65	Water flow control faulty (does not stop flow properly)	Service Call
71	Micro-processor failure	Service Call
72	Flame rod circuit error	Service Call
LC (00)***	Scale build-up in heat exchanger	Service Call

* In all cases, you may be able to clear the Error code by turning the hot water tap OFF, then ON again. If this does not clear the error, try pushing the On/Off button OFF then ON again. If the Error Code still remains contact Rinnai or your nearest service agent for advice.

** Faults caused by insufficient gas/water supply or gas/water quality and installation errors are not covered by the manufacturer's warranty.

*** The display will alternate between temperature setting and LC code. The controller will continue to beep. The LC code will reset if power is turned Off and then On.

ERROR MESSAGES

Troubleshooting without controllers

If you have not installed temperature controllers and experience the following symptoms, please carry out the suggestions below. If symptoms continue, please contact Rinnai for advice.

NOTE: Faults caused by insufficient gas/water supply or gas/water quality and installation errors are not covered by the manufacturer's warranty.

Fault	Remedy
Heater does not attempt to start at all.	Check the power is on at the heater. Check the cold water valve supplying the heater is open.
Heater starts then shuts down immediately.	Check the power is on. Open the hot water tap fully. Check the gas valve at the heater and at the gas meter is fully open.
Heater starts then water goes cold.	Check the power is on. Open your hot water tap further or try another hot outlet.

Installations with circulation pumps

With temperature controller fitted.

If you have an installation using a secondary circulation pump this must be switched off so that there is no flow through the heater when starting or after a power failure. If the pump is running the unit will not operate (no display on the controller). Isolate pump then start heater before restarting pump. This is a safety feature. The pump should also be fitted with a timer to prevent the consumption of energy while the building is not used. The timer should bring the system back on at least one hour before it is to be used.

Without temperature controller fitted.

The heater should automatically reset and provide water at the temperature set by the internal limit switches.

RESTARTING THE RINNAI WATER HEATER

Standard system.

Single or multiple water heaters without remote controllers.

The heaters will automatically reset without any user involvement.

Single or multiple water heaters with remote controllers.

The heaters will be required to be switched on using the ON/OFF button on a remote controller. Ensure that all taps/water outlets are closed and no water is flowing through heaters.

Hot water system incorporating secondary recirculation pump.

Single or multiple water heaters without remote controllers.

The heater(s) will automatically reset without any user involvement.

Single or multiple water heater(s) with remote controller(s).

To reset the heaters follow the steps.

1. Turn off all hot water taps.
2. Turn off supply to secondary circulating pump or alternatively, isolate pump flow.
3. Turn on heater at remote control.
4. Select required temperature.
5. Switch on supply to secondary circulating pump or open valve on pump flow.

The heater will now be ready to supply water at the set temperature.

If following the above procedure does not reset the heater switch it on and off at its main supply, and then go through these steps again. If heater is still not working call your local service agent or Rinnai for assistance.

UK CARING AND MAINTENANCE

Maintenance

Even if there does not seem to be a problem with the water heater it is required in the UK that all gas appliances are serviced every year by a certified gas engineer. This is to ensure continued safety of the gas appliance. If you need a recommended service engineer contact Rinnai or your supplier. For more detailed instructions on maintenance contact Rinnai or your supplier.

Care

When the appliance casing, operation panel, and remote controls surfaces become dirty gently wipe them clean with a soft, damp cloth. Do not use detergents on these parts.

Filter

The water heater has a filter on the cold water inlet connection. This filter will need to be cleaned occasionally. How often will be determined by the local water conditions; contact Rinnai or ask your installer for information.

Isolate the cold water inlet and hot water outlet with the valves near the heater. Release the pressure in the heater by unscrewing the drain valve. Then remove the filter, clean it and replace it.

INSTALLATION INSTRUCTIONS

STOP

To go beyond this point in the manual you must be a registered gas engineer.

Do not attempt to install this appliance if you are not qualified.
This can void the warranty.

If the information in this manual is not followed exactly a fire or explosion could result.

This manual must be read in its entirety before installing the appliance.

If you are unsure of any point contact Rinnai or your supplier.

UK INSTALLATION INSTRUCTIONS

IMPORTANT INFORMATION

This appliance may only be installed by someone certified competent to do so. At the time of printing the only people deemed competent to install this appliance are those that are GAS SAFE registered for this type of appliance in this type of location who have a current ACS certificate.

1. **Gas safety (Installation & Use) regulations 1998** are the 'Rules in force'. In your own interest and that of safety, it is law that all gas appliances are installed by competent persons in accordance with the above regulations. Failure to install appliances correctly could lead to prosecution. Other persons should NOT attempt to install this equipment.
2. **Building Regulations G3** require installers of unvented systems to be competent to do so. Competence can be shown by holding a current certificate in Unvented Domestic Hot Water Systems. If the Rinnai is installed in a flow and return, or tank system, or any other closed system then the system is unvented.
3. Installation must be carried out in accordance with the current issue of the following:
Building Regulations issued by the Department of the Environment
Building Standards (Scotland) Regulations.
I.E.E. Wiring regulations for electrical installations.
Gas safety (Installation and Use) Regulations current issue.
BS 5546
BS 5440
BS 6891
BS 5482
BS 6700
BS 6644
Institute of Gas Engineers Publications
Local byelaws
Water regulations
Health and safety at work etc. Act 1974
IGE/UP/10 Part1 Edition 2.
Building Regulation J and G
Such other specifications and regulations that may supersede or complement the above documents. It is the installer's responsibility to ensure that the unit has been installed to all current requirements.

Please be sure that you are fully aware of your obligations and responsibilities under these regulations.

In case of defect parts only use genuine Rinnai components for replacement.

Attention: air surrounding the water heater, venting and vent termination(s) is used for combustion and must be free of any compounds that cause corrosion of internal components. These include corrosive compounds that are found in aerosol sprays, detergents, bleaches, cleaning solvents, oil based paints/ varnishes, and refrigerants. Therefore Rinnai recommends outdoor models be used for these locations where possible. The water heater, venting and vent termination(s) should not be installed in any areas where the air may contain these corrosive compounds. If it is necessary for a water heater to be located in areas which may contain corrosive compounds, Rinnai strongly recommends the following:

Indoor/Internal Water Heaters:

- * DO NOT install in areas where contaminated air is present
- * Consider before installation where air has the ability to travel within the building
- * Where possible, install the water heater in a sealed closet so that it is free of contaminated indoor air
- * Chemicals that are corrosive in nature should not be stored or used near the water heater

Outdoor/External Water Heaters and Vent Terminations of Indoor/Internal Water Heaters:

- * Install as far away as possible from exhaust vent hoods
 - * Install as far away as possible from air inlet vents. Corrosive fumes may be released through these vents when air is not being brought in through them.
 - * Chemicals that are corrosive in nature should not be stored or used near the water heater or vent termination.
- Damage and repair due to corrosive compounds in the air is not covered by warranty.







Disposal Information:

Under the laws and local regulations, this product must be disposed separately from household waste. When this product reaches the end of useful life, it should be taken to a collection point identified by the local authorities. The recycling of the product at the time of disposal will help conserve natural resources and ensure that it is recycled in a manner that protects human health and environment.

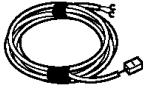

UNPACKING RINNAI WATER HEATER

- After unpacking the appliance check for damage, if the heater is damaged contact your supplier immediately. Do not install a damaged appliance before checking with your supplier.
- A heater accessories pack is inside the carton. The 26i model has a built-in remote control on front of the appliance. Remote controllers are not supplied with the Rinnai HD range of heaters because they are commercial units. If you require controllers in commercial situations they are compatible with the HD range and available from Rinnai or your supplier.
- Check that the appliance supplied is the correct gas type and pressure for the installation. Refer to the data plate located on the left-hand side of the appliance.
- Remove the heater and the accessories from the carton, and check that all the parts are included. The remote control cable is provided with spade connectors.

Remote Control Parts

Quantity	Diagram	Description
1		Temperature controller MC-91
1		Cable Clamp (to fix one Control Cable)
1		Cable Clamp (to fix two Control Cables)
5		Spade Connectors
1		Control Cable 20 metres
1		Clamp Screw

Unit Mounting Fasteners

Quantity	Diagram	Description
5		Screw
5		Wall Plug

OPERATION

Ignition

Press ON/OFF button of remote controller to turn on unit and the remote controller display and priority LED will light up. When a hot water tap is opened the water flow sensor revolves and sends a pulse signal to the printed circuit board (PCB). When the PCB detects water flow it compares the measured temperature to the temperature setpoint. If required it begins the ignition process with the combustion fan motor starting first. Once the air proving is made the main solenoid valve and change-over solenoid valves are opened and the burner is lit by the sparking igniter.

Temperature Control

Once the flame rod proves ignition the heat modulates by controlling the gas rate, combustion air, and water flow to precisely heat the water. This control is done by measuring the outgoing water temperature with a thermistor.

Standby

When the hot water tap is closed the PCB no longer receives a pulse signal from the water flow sensor. The PCB shuts the main solenoid valve and change-over solenoid valves and the burner extinguishes.

OPERATION

HD50e

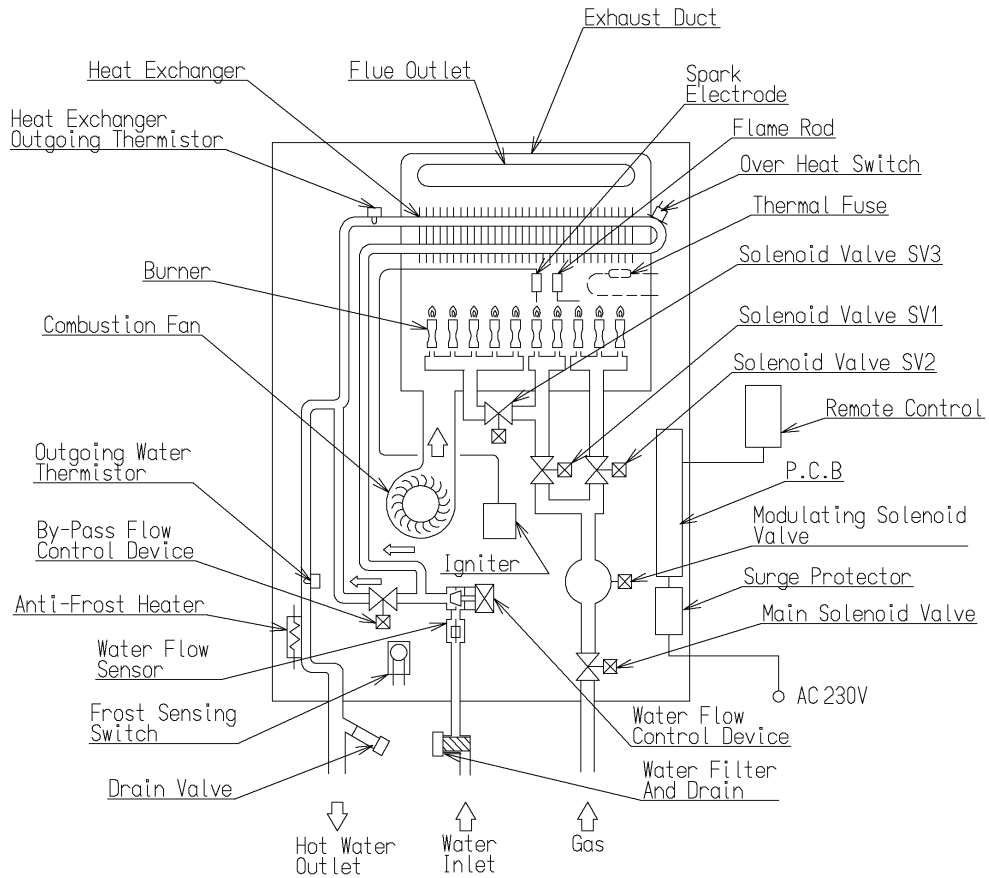

26i - HD50i

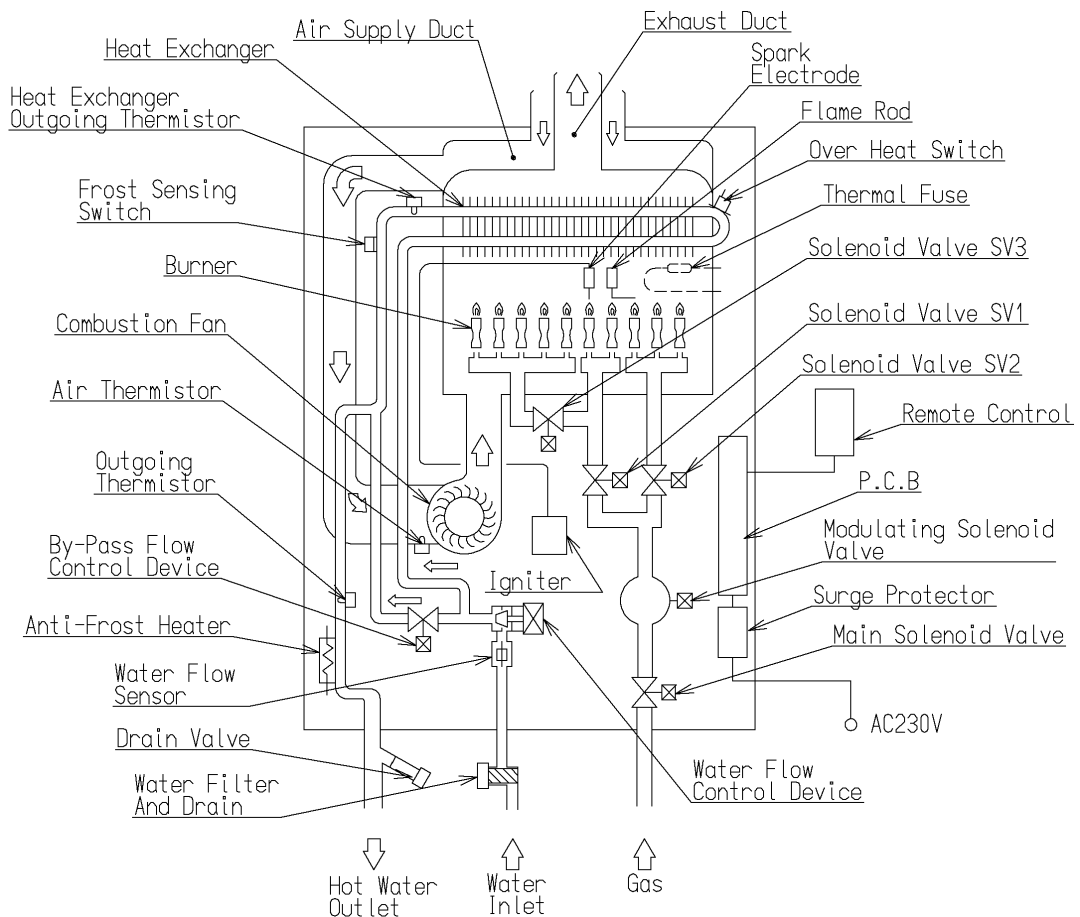

OPERATION

HD70e

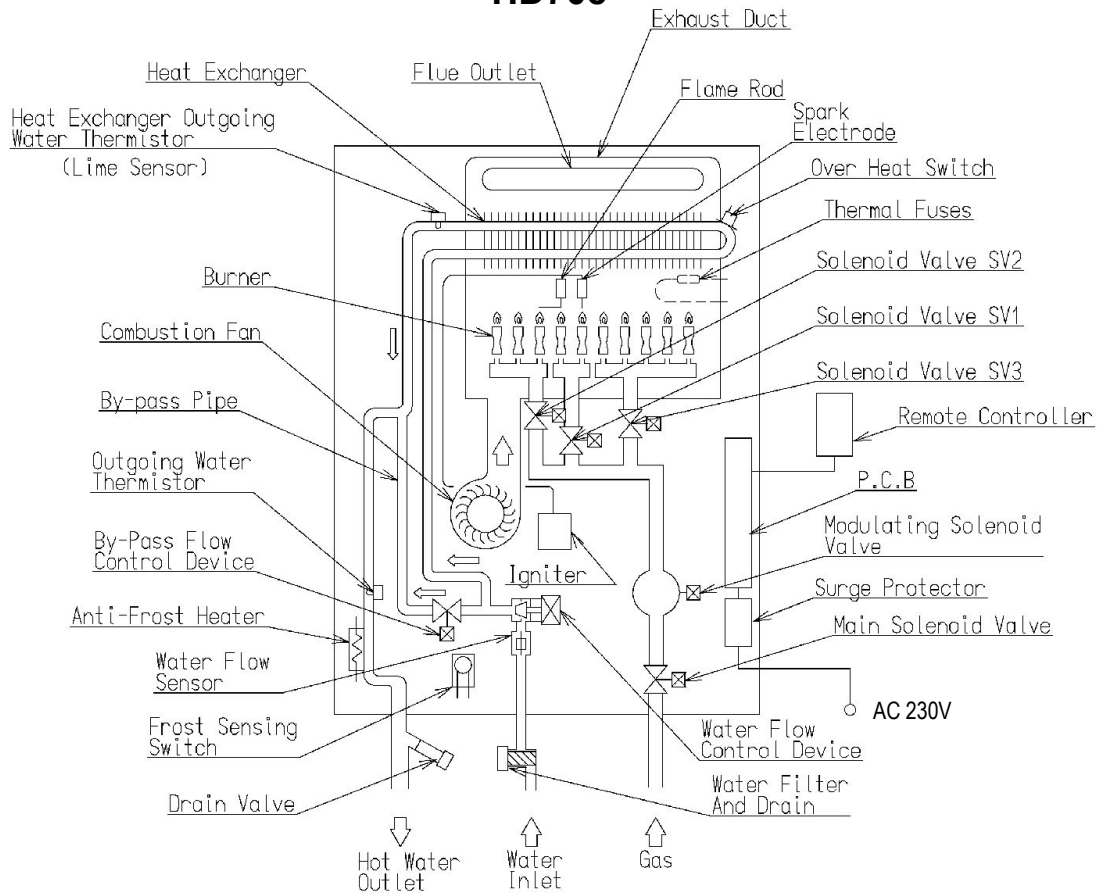

HD70i

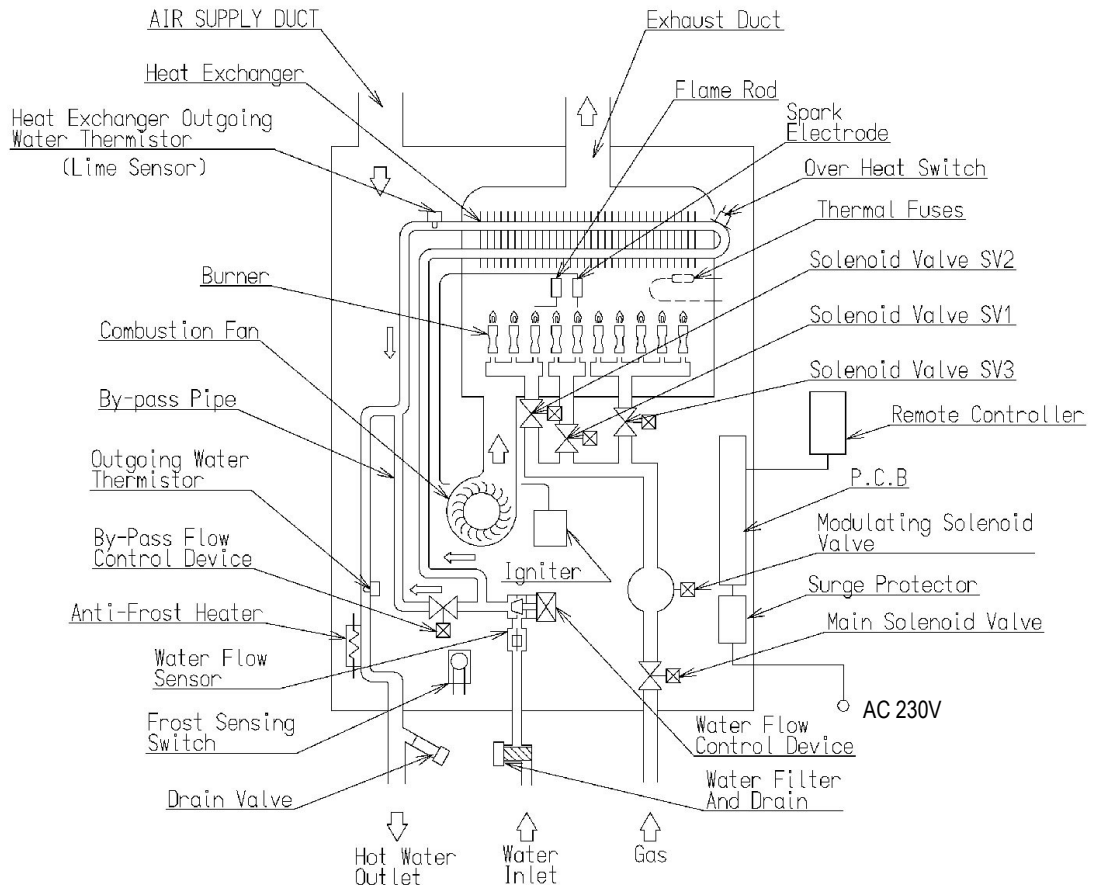

MAIN COMPONENTS

1. Gas Control Unit

1.1 Modulating Valve

This device is used by the PCB to adjust the volume of gas to the burner in proportion to the volumetric flow rate of water in order to maintain a supply of constant temperature hot water amid changes in water flow rates and incoming temperatures.

1.2 Change-over Solenoid Valves

Additional solenoid valves are included to section the burner and stage the control in several steps. This gives the burner more steady combustion at the required capacity and allows the water heater to operate at very low flow rates and temperature rises.

2. Flame Rod

Monitors combustion characteristics inside the combustion chamber. If the flame fails, gas supply is stopped. Works through rectification of the combustion flame. An AC voltage is supplied to the flame rod. Electrons can only pass from the rod to the earthed burner through the flame, and never from the burner to the rod, so the resultant DC current is used to prove combustion. When the DC current is present the burner has normal combustion, if the DC current is not present (or an AC current is present) the unit shuts the solenoid valve.

3. Thermal Fuse

The thermal fuse is an electric link which must be intact for the unit to operate. If the thermal fuse reaches a set temperature it will melt and the unit will shut down. The thermal fuse must be replaced if it melts. It is to protect against overheating and heat exchanger splits where water may leak out and be superheated into steam.

4. Overheat Safety (Bi-metal Switch)

This Bi-metal Switch is fixed at the inlet bend of the Heat Exchangers final pass. If the temperature outlet from the heat exchanger reaches 97°C the bi-metal switch will open and the solenoid valve circuit is broken. This will cease combustion in case of overheat.

5. Combustion Fan

The combustion fan supplies primary air into the burner wings and secondary air up through the Bunsen style burners. The fan is DC low voltage and the speed is controlled by the PCB depending on the hot water supply and temperature. The fan speed is compared to the current required to attain that speed for air proving. If the fan current is over or under the parameters for the given speed the unit will shut down on air proving.

6. Water Flow Servo with Water Flow Sensor

6.1 Water Flow Sensor

Water flow sensing is done with a small turbine that spins when water travels through it in the correct direction. Each of the four fins on the turbine has a small magnet on it. Outside of the valve there is a magnetic sensor that detects the speed that the turbine is revolving. The revolution speed is input to the PCB which relates this speed to the water flow volume and determines whether it is sufficient for ignition.

6.2 Water Volume Flow Servo

Water flow control is achieved through the use of servo driven water flow and bypass valves. The servo motor is controlled by the PCB. The 'Water Flow Valve' restricts the flow of water into the heat exchanger assembly if the programmed temperature cannot be achieved. This will limit the maximum water flow, and will limit the hot water flow further when the burner is at high fire to ensure the temperature setpoint is met.

INSTALLATION INSTRUCTIONS

External Models

The HD50e and HD70e water heaters are designed for '**Outdoor**' installation only. As such, it must be located in an above ground, open air situation with natural ventilation, without stagnant areas, where products of combustion are rapidly dispersed by wind and natural convection.

It is important to ensure that the air inlets, which are located on the front and lower back panels (HD50e), are not restricted or blocked in any way.

The exhaust slot on the front should follow the same location guidelines as a balanced flue terminal. Ensure that the flue terminal and hot water outlet connection cannot be touched by children. The exhaust slot must be clear of obstructions and shrubbery. Multiple heater installations can be installed with the heaters manifolded together. When positioning appliance the flue terminal clearances must be in accordance with local requirements. Consideration should be given to other appliances, openings, and boundaries.

Internal Models

LPG appliances may not be installed in basements or below ground level.

The 26i/HD50i and HD70i are designed for '**Indoor**' installation only. It may be installed 'Outdoors' in an enclosure (enclosure is defined as a compartment, enclosed area or partitioned off space primarily used for the installing of the appliance). If installed in an enclosure, either internally or externally, the location should be ventilated and provision must be made for the safe disposal of any leaking water to an exposed location.

When positioning appliance the flue terminal clearances must be in accordance with local requirements. Consideration should be given to other appliances, openings, and boundaries. Multiple heater installations can be installed with the heaters manifolded together. The minimum distance required between the heaters may then be based on the necessary clearances between flue terminals. The internal units may not be installed in a humid area.

All Models

The wall or structure on which the heater is mounted must be capable of supporting the weight of the appliance (listed on **page 42-43**) and associated pipework.

The heater must be installed in a vertical position with the gas and water connections on the underside pointing downward.

Ensure that suitable screws or bolts are used to secure the water heater to the wall. Bracket and fixing hole locations are shown on the template included. The top bracket has a keyhole slot so that the appliance can be hung on one screw, and then the other fixings can be added to secure the unit.

The appliance should be placed as close as practical to the most frequently used hot water outlet point or points to minimise the delay time for hot water delivery. For installations where the distance between the unit and hot water outlet points is considerable, the appliance can also be fitted in a 'flow and return system' which minimises the waiting time for hot water delivery. Alternatively, multiple appliances can be strategically placed to service outlet points with minimal delay time.

Contact Rinnai or your supplier for further information.

THIS APPLIANCE MUST NOT BE USED AS A DOMESTIC SPA OR SWIMMING POOL HEATER.

Please consider the location of the appliance and what is below it. As with any water fitting there is a possibility that a connection or component could develop a leak over time; or water may spill during servicing of the appliance. Rinnai can not be held responsible for any consequential water damage so it may be necessary to fit a drain pan under the unit.

INSTALLATION INSTRUCTIONS

Clearance

The appliance must be in an accessible location. Sufficient clearances shall allow access to, and removal of, all serviceable components. The following clearances should be followed. It is important not to block any of the air inlets which are located on the front and lower back panels of the case on the HD50e

(Clearances in mm)	From Combustibles		From Non-Combustibles	
	Internal range	External range	Internal range	External range
Above	300	300	50	50
Behind	0	0	0	0
In Front	600	600	600	600
Sides	50	150	15	15
Below	300	300	50	50
Flue pipe	20	-	0	-

Water Supply

Where the water supply pressure exceeds 10 bar, an approved pressure reducing device must be fit at the inlet of the appliance. To achieve the maximum rated flow a minimum water supply pressure of 1.4/2.0 bar (see **pages 42-43**) is required at the appliance inlet. The unit will operate at lower supply pressures but the maximum flow rate will not be achieved. Most installations will use high temperature setpoints which will reduce the available flow rate and heat exchanger pressure drop, and therefore less pressure will be required at the inlet. See the pressure chart on **page 48**.

Contact Rinnai or your supplier for 'gravity fed' or 'low pressure' hot water installations.

Water pipe sizing and layout should be designed correctly to ensure the given water flows from the appliance are available. All hot water pipework should be insulated to optimise maximum performance and energy efficiency.

Water Connection

Connect the hot and cold water supply pipes as shown on **page 25**. An approved isolation valve and strainer **MUST** be installed in the cold water inlet pipe. An approved isolation valve and draining point should be installed in the hot water outlet pipe. There must be a union or release fitting on the heater side of the isolation valves. An unvented kit to local regulations must be installed in the pipework when the system is closed (i.e. has a flow and return, or tank). Positions of the cold water inlet, hot water outlet and gas connections are shown on **page 25**.

If the heater is in a hard water area a suitable water conditioning device must be installed to prevent the build up of limescale within the heat exchanger. Heat exchangers damaged by scaling are not covered by the manufacturer's warranty.

Description	pH	Total Dis-solved Solids (TDS)	Total Hard-ness	Chlorides	Magnesium	Calcium	Sodium	Iron
Maximum Recommended Levels	6.5 - 9.0	600 mg/litre	150 mg/litre	300 mg/litre	10 mg/litre	20 mg/litre	150 mg/litre	1 mg/litre

Gas Connection

Check pipe sizing required for the heater input. The heat input for the water heater is shown on **page 42-43**. The size of the gas meter (or regulator) and pipework must be sufficient for all appliances on the main. Sufficient gas must be available at the appliance if correct operation is to be expected; insufficient gas will damage the unit. An approved gas isolation valve must be fitted at the gas inlet. A union or release fitting should be installed after the isolation valve.

Electrical Connection

The appliance must be earthed. The appliance is suitable for 230V AC – 50Hz mains only and all wiring must be carried out to local regulations.

UK INSTALLATION INSTRUCTIONS

Water Connection

For all closed systems (with flow and return or tank) the system must incorporate an unvented kit with the components shown below. The safety relieve valve must discharge safely into a suitable drain via a tundish.

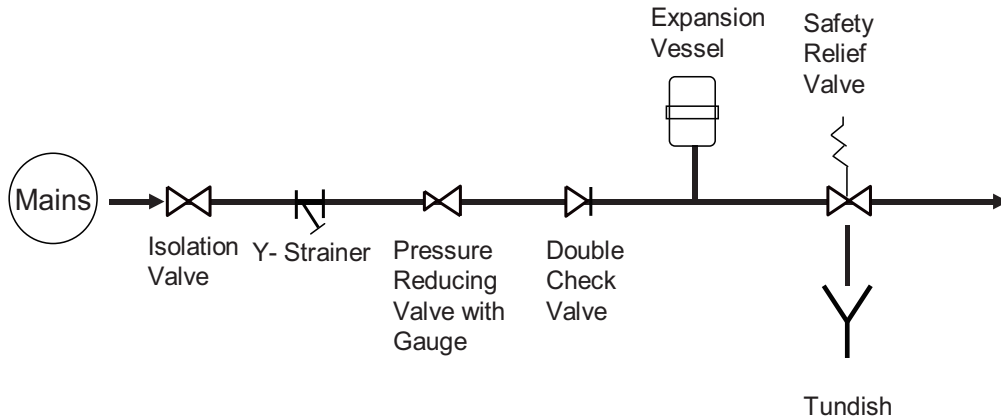

Gas Connection

Refer to BS6891 (Natural Gas) and BS5482 (Propane) for guidance on correct pipe sizing calculation. There must be 20 mbar Natural Gas (G20) or 34.5 mbar Propane (G31) at the inlet of the appliance with all appliances at high fire.

Electrical Connection

The heater electrical supply must be installed to the latest I.E.E. regulations. If the unit is hard wired (moulded plug removed) it must be provided with a fused (5A) local isolator with a contact separation of 3mm minimum on all poles for servicing. Observe polarity and ensure that wiring is correctly restrained.

Direct Flow

Rinnai
Quality Is Our Destiny

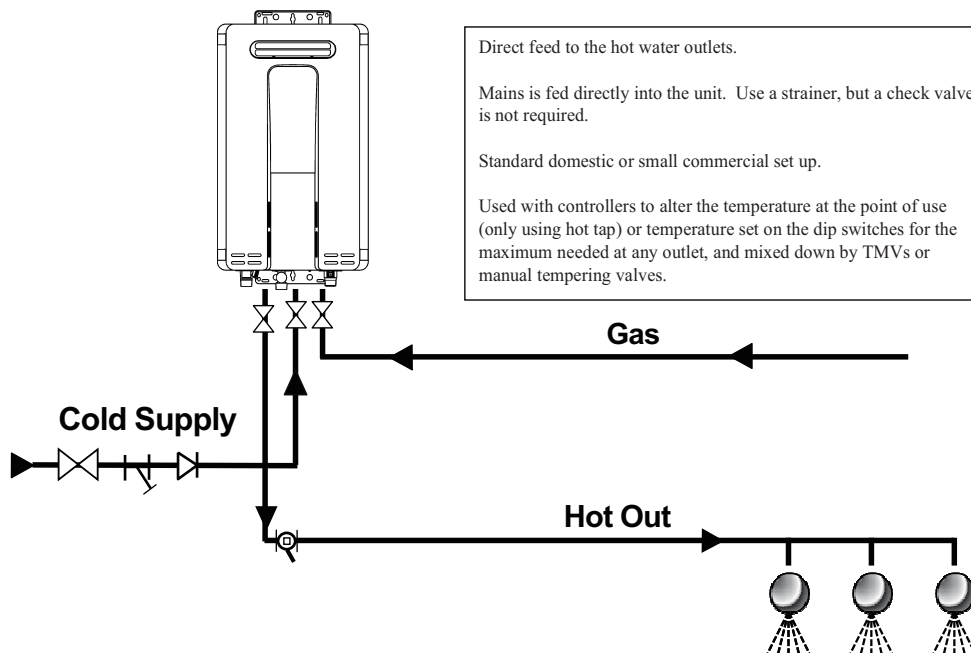

This information is intended as a guide only, it does not imply compliance with water or gas installation regulations. Components will vary depending on the actual installation. Check local regulations before installation.

 Draining Point

Hot Outlets

UK INSTALLATION INSTRUCTIONS

General Information on the internal range of water heaters.

This appliance must be installed in accordance with the rules in force. Consult instructions before installations and use of this appliance. The unit must be installed by a competent, authorised person. It is the installer's responsibility to ensure that the unit has been installed to all current requirements.

The Rinnai internal water heaters are room sealed appliances. Ventilation requirements of BS 5440 allow room sealed appliances to be installed in spaces and rooms, including bedrooms, without ventilation. If the appliances are installed in a compartment, it must have the following amount of permanent ventilation:

- ventilation from compartment to room:
220 cm² at high level AND 220 cm² at low level; based on 10cm²/kW gross heat input;
- ventilation from compartment directly to outside:
110 cm² at high level AND 110 cm² at low level; based on 5 cm²/kW gross heat input.

The area given is the free area of the vent or equivalent free area for ventilators of more complex design. Any space taken up by grille louvers should be subtracted from the total area to find the free area of the vent. Windows and doors can not be considered ventilation unless they are permanently fixed in the open position.

Please refer to IGE/UP/10 Part 1. Edition 2 page 17; for further information or contact Rinnai UK.

FLUE REQUIREMENTS

The flue must be installed by a competent, authorised person. It is the installer's responsibility to ensure that the unit has been installed to all current local requirements.

Ensure that the flue terminal and hot water outlet connection cannot be touched by children. The flue must be clear of obstructions and shrubbery.

HD70i

Concentric Flues: a two pipe to one pipe adapter can be fit directly on the unit over the two connections. This will transfer the parallel pipe system into a single, coaxial, 100mm diameter inner pipe/150mm diameter outer pipe, flue system. This is used for flueing the appliance directly through the wall behind where the unit is mounted. It cannot be used with extensions.

Parallel Flues: for flue extensions a concentric flue cannot be used because of internal temperatures in the heater. Using an extended concentric flue can damage the heater - any damage caused in this way will not be covered by warranty. For extension applications the exhaust and the air inlet should be run separately to the point of termination. The extensions are 100mm diameter stainless steel male/female ducts. At the point of termination a concentric flue terminal can be used. This type of termination allows the extra distance necessary, but only requires one hole in the wall or roof. If a two pipe terminal is used the exhaust pipe must be on top.

Flue Length: The HD70i has two separate, parallel connections on the top of the unit. The centred one is for the exhaust and the one to the left is for the combustion air intake. The maximum flue length for parallel flueing is 13m total equivalent length. This is for the exhaust and the air intake; therefore 13m of exhaust and 13m of air intake are allowed. From total equivalent length subtract 2m for 90° bends and 1m for 45° bends. There is no limit to the minimum length of the flue.

Installations with total equivalent length of flue >7m must alter the flue length Dip Switch (see **page 36**).

Common Header (Cascade) Flues: do not connect this appliance into any common header flue, cascade system, or natural draught chimney. For information on these installations contact Rinnai.

FLUE REQUIREMENTS

26i / HD50i

Concentric Flues: a single, coaxial, 80mm diameter inner pipe / 125mm diameter outer pipe, flue system can be fit directly on top of the water heater.

Flue Length: the maximum flue length for coaxial flueing system is 13m total equivalent length. From total equivalent length subtract 2m for 90° bends and 1m for 45° bends. There is no limit to the minimum length of the flue.

Installations with total equivalent length of flue >7m must alter the flue length Dip Switch (see **page 36**).

Bend Flue	0 bend	1 bend (90°)	2 bend (90°)	3 bend (90°)	4 bend (90°)	5 bend (90°)
1m						
2m						
3m						
4m						
5m						
6m						
7m						
8m						
9m						
10m						
11m						
12m						
13m						

SHORTEST FLUE (factory setting)

LONG FLUE

NOT ALLOWED

Common Header (Cascade) Flues: do not connect this appliance into any common header flue, cascade system, or natural draught chimney. For information on these installations contact Rinnai.

Condensate disposal internal models

It is important that any condensate is kept away from the heat exchanger. The flue should tip away from the unit without a condensate trap, and towards the unit if there is a trap. Condensate kits are not required if the flue is directly through the wall behind the unit. For these installations the terminal should slope gently to the outside to prevent ingress of rain. Although no condensate is expected in flue runs this short a small amount may occur at start up on very cold days. Care should be given to the placement of the terminal to prevent risk from condensation. Condensation water can cause burns, and during winter could create a slip hazard. It is the responsibility of the installer to decide the best place for the terminal.

Flue lengths less than 1,5m do not require condensate disposal and the cap can be left on the condensate collector component. Flues over 1,5m must have a condensate disposal method. For flue runs with condensate disposal the horizontal sections should slope back towards the appliance and the rain terminal should be used. The rain terminal should be mounted level through the wall. The flue should be bracketed to prevent sagging. The drain pipe should be run in 22mm PVC, uPVC, or ABS pipe, copper is not recommended. The drain pipe MUST be trapped.

FLUE REQUIREMENTS

For the Internal range the flue system is considered part of the continuous flow water heater. The following flue type and make is approved in combination with above mentioned water heaters. Separate instructions are provided with the flue detailing the installation of the flue parts.

Ubbink flue system for HD70i:

952-032-001	HD70i standard horizontal kit
952-032-002	HD70i 45° bend
952-032-003	HD70i 90° bend
952-032-006	HD70i flue extension L=1m
952-032-007	HD70i vertical flue kit
952-032-008	HD70i flat roof flashing 150Ø
952-032-011	HD70i lead tile 25°-45° roof
952-032-017	HD70i lead tile 5°-25° roof
952-032-022	HD70i horizontal extension kit

The first flue component on the heater must be a special vertical female/female discharge adaptor. The centre, exhaust adapter has integrated condensate trap, but the air intake does not. For terminations straight through the wall the special horizontal adapter for short flue lengths is used. Never use an extension as the first component, they will cause damage to the water heater and the flue system. Secure flue connections with pipe clamps or perforated hanger iron. Please see **page 29** for recommended terminal positions.

Ubbink flue system for 26i / HD50i:

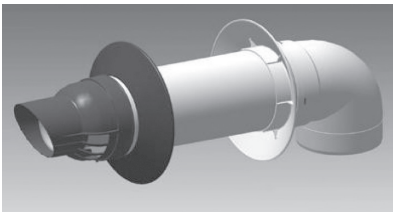

26i/HD50i Standard Horizontal Kit
Ø80 -125mm



26i/HD50i 90° Bend
Ø80 -125mm



26i/HD50i Vertical Flue Kit
Ø80 -125mm

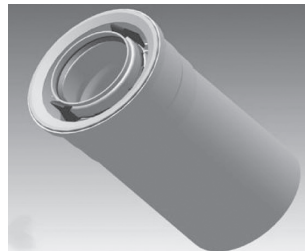

26i / HD50i Extension
1m x Ø80 -125mm

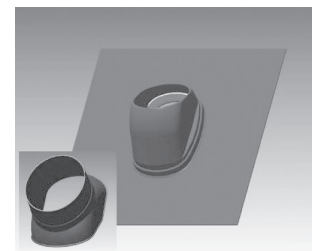

26i/HD50i Lead Tile
25° - 45° Roof

Warning: Before installation inspect each flue component for damage and correct seal placement. Do not attempt to fix or install any damaged component. Improper installation of flue systems or components, or failure to follow all installation instructions can result in property damage or serious injury.

UK FLUE REQUIREMENTS

The Rinnai internal range are for internal installation in conjunction with the Rinnai flue system.

The flue must be installed in accordance with:

- Manufacturers Installation Instructions;
- Gas Safety (Installation and Use) Regulations;
- Building Regulation J.
- British Standards including BS5440;
- IGE/UP/10 Part1 Edition 2;

Such other specifications and regulations that may supersede or complement the above documents.

The flue must be installed by a competent, authorised person. It is the installer's responsibility to ensure that the unit has been installed to all current requirements.

Location of the appliance flue terminal must be in accordance with the clearances shown in BS5440-1:2000. Table and Figure C.1 is provided below for your guidance:

The flue terminal should be over 2m from ground level whenever possible.

For lower installations a terminal guard must be installed.

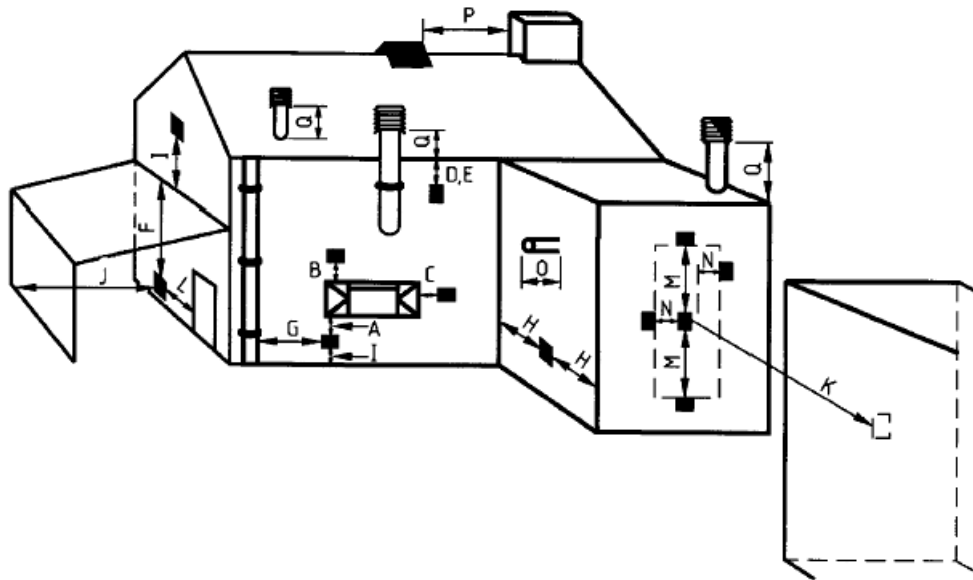

	Terminal Position	Distance (mm)
A	Directly below an opening, air brick, opening windows, etc.	300
B	Above an opening, air brick, opening window, etc.	300
C	Horizontally to an opening, air brick, opening window, etc.	300
D	Below gutters, soil pipes or drain pipes.	75
E	Below eaves.	200
F	Below balconies or car port roof.	200
G	From a vertical drain pipe or soil pipe.	150
H	From an internal or external corner.	200
I	Above ground, roof or balcony level.	300
J	From a surface facing the terminal.	600
K	From a terminal facing a terminal	1200
L	From an opening in a car port. into a dwelling	1200
M	Vertically from a terminal on the same wall.	1500
N	Horizontally from a terminal on the same wall.	300
O	From the wall on which the terminal is mounted	N/A
P	From a vertical structure on the roof.	N/A
Q	Above an intersection with roof.	N/A

TEMPERATURE CONTROLS

General Information

Commercial installations do not generally have controllers installed. These installations usually have one permanent set temperature that is constant at all times. The public should not have access to alter the temperature in these situations. These installations do not require controllers as the temperature can be set by a series of dip switches on the PCB.

Exceptions to this are the following:

1. Circumstances where the required temperature is not available with the dip switches (for example 41°C or 47°C).
2. Circumstances where the temperature needs to be raised periodically by the building occupant in order to flush the system.
3. Domestic situations where the user needs control of the temperature of the water so that different temperatures can be used at different outlets.

In situations such as 1 and 2 the controllers should be installed in places out of reach of the public, such as in the maintenance room or in a locked cupboard.



This **Commercial Setting** will allow the controller to come back on automatically after a power cut at the temperature setpoint previous to the power cut, regardless of whether water is flowing through the unit. This should only be used for commercial installations.

NEW FEATURE

The maximum temperature available on the primary universal remote controller is the set point on the dip switches. If only one controller is installed it will not go beyond 50°C when first installed. To bypass this see **page 11**.

Positioning the temperature controls, the following points should be taken into account:

- Fit the controls out of reach of children (suggested height from the floor 1.5m).
- Avoid positions where the controllers will become hot. Do not fit them near stoves or ovens, or above radiators or heaters.
- If possible, avoid exposure to direct sunlight or positions where bright lights will make the digital display difficult to read.
- Position away from areas where the controller will be prone to splashing by cooking products such as oils and fats.
- The temperature controllers are water resistant, however they should be positioned away from areas where direct or persistent splashing could occur.
- Refer to the local electrical wiring regulations current edition for location requirements in shower and bath areas.
- The cables to the temperature controller carry only 12VDC (extra low voltage).
- When using more than one temperature controller the signal cable should be run in parallel. Do not wire the controllers in series.

The installation in every application will vary, therefore the temperature controller cable has been provided so that you may cut the length accordingly and fit the spade connectors, ensuring a good connection.

Cables are simply 'piggy-backed' at the water heater or at the primary temperature controller. Polarity is not important when connecting the cables, either colour wire can be connected to either terminal at both the heater or primary temperature controller. If more cable is needed any cable with similar specification to the cable supplied with the controller can be used. Maximum length is 50m.

Controller Connection in Parallel

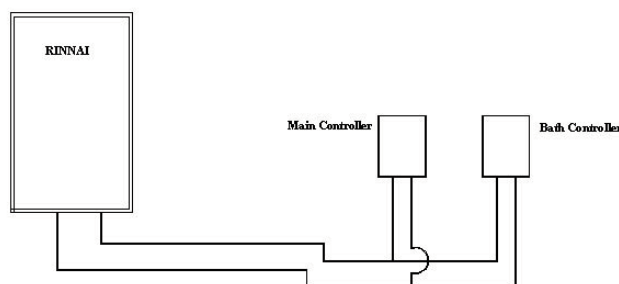

TEMPERATURE CONTROLS

Universal temperature controller - MC-91

1. Determine the most suitable position for the temperature controller.
2. Drill 3 holes in the wall (Fig.1), one for the cable and two for the securing screws. Fit wall plugs if needed and ensure controller is level.
3. Run the cable provided through the hole in the wall ensuring that the end fitted with the connector is nearest the controller (Fig.2).
4. Remove the face plate from the controller using a flat screwdriver (Fig.3).
5. Connect the cable to the temperature controller.
6. Fix the controller to the wall and fasten with the Phillips head screws supplied as shown in (Fig.4).
7. Remove the protective plastic film from the controller face.
8. Replace the face plate.

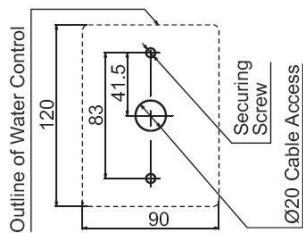

Fig. 1

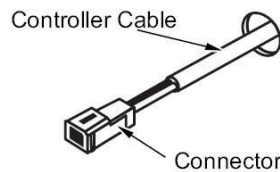

Fig. 2

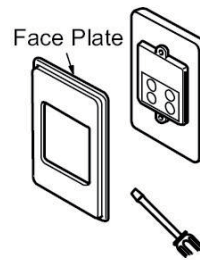

Fig. 3

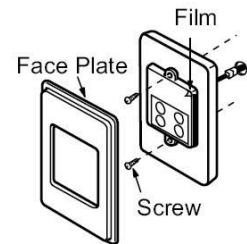

Fig. 4

32 Liters: Connecting one or two controllers

1. Isolate the electric power supply.
2. Remove the retaining screw of the quick cable connector door located at the base of the appliance (A) (Fig.5).
3. Thread the water controller cable through the weather seal of the cable access hole (B) (Fig.6) in the direction shown allowing sufficient cable length so that the sheath of the cable can be secured with cable clamp (C) supplied with the water controllers (Fig.7).
4. Loosen the screws on terminals (D) and (E). Connect the spade connectors of the controller cables to these terminals. Tighten the screws on terminals (D) and (E). Polarity is not important, either wire colour can be connected to either terminal (Fig.8).
5. Return the quick cable connector door to the original position taking care not to damage controller wires and replace the retaining screw.



Fig.5

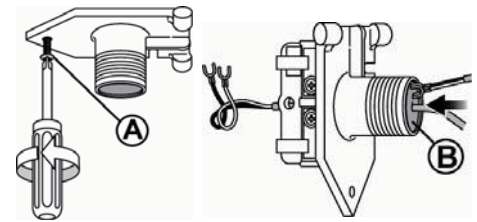

Fig.6

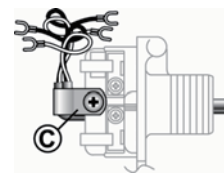

Fig.7

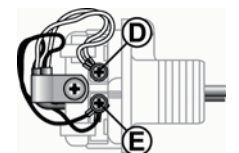

Fig.8

26 Liters: Connecting one or two controllers

Follow 32 Liters procedure from step No.3 but referring to Fig.9.

Connecting three or four controllers

Repeat steps 1, 2 and 3 above.

- Cut the spade connectors from two of the controller cables to be connected to the appliance (4 spade connectors should be cut off) and discard. Connect the wires from these two cables and terminate into two new spade connectors as shown in Fig.10. Spade connectors are supplied with the controllers. Repeat steps 4 and 5 above.

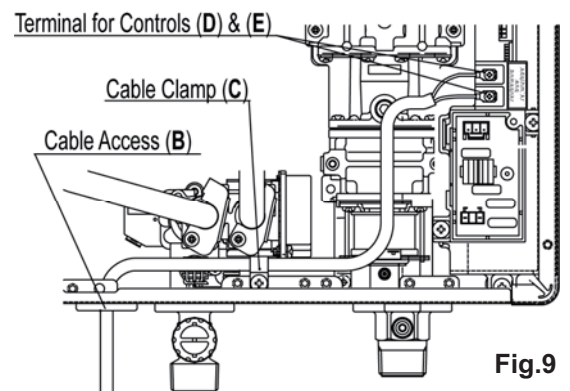

Fig.9

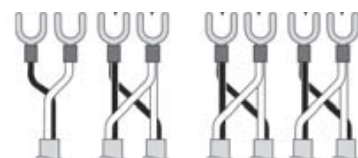

Fig.10

EZ CONNECT



NEW FEATURE

EZ Connect Installation

The EZ Connect allows the installation of two water heaters to be controlled by one remote controller without PAM valves or a MECS. The EZ Connect will sequence the heaters for low flows and rotate the lead heater for even use.

Installing the EZ Connect

1. Install the two water heaters from 50mm to 450mm apart so that the EZ Connect cable will reach between the two.
More than 450mm apart can cause temperature fluctuations.
2. Remove the protective cap from the 3 pin connector marked EZ Connect located in the wiring harness of the Primary Unit. (Fig. 1)

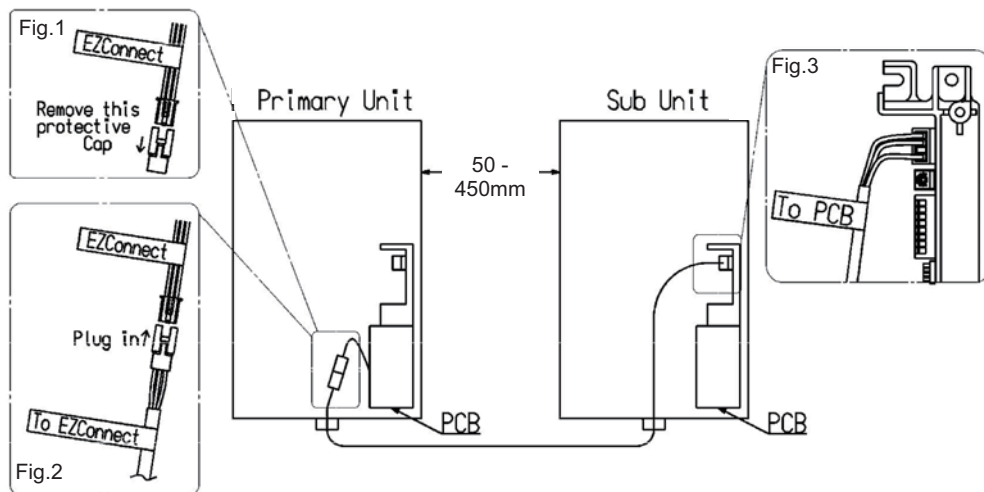

3. Plug in the EZ Connect cable. The end marked "To EZ Connect" connects in the primary water heater to the 3 pin connector seen in Fig. 2. The other end, marked "To PCB", connects to the empty plug at the top of the PCB of the other water heater (sub unit.). (Fig. 2 and 3)
4. Securely fasten the EZ Connect cable to the bottom of each water heater with the cable clamps and screws supplied. (Fig. 4)



NOTE

- The EZ Connect cannot be used with the MECS.
- The EZ Connect cannot use the Bath Fill Function
- The temperature can only be changed on the primary unit's controller.
- PAM valves are not required.

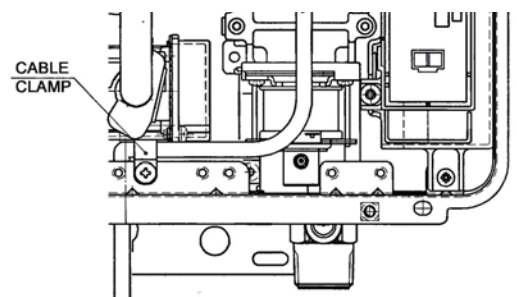

Fig. 4

TESTING



1. Purge gas, hot water and cold water supply lines before making the final connection of the water heater. Swarf in either the gas or water supplies may cause damage.
2. Turn on gas and cold water supplies.
3. Test for water leaks and gas escapes near the unit.
4. Isolate gas and electric supply. Remove test point screw located on the inlet gas pipe work below the heater and attach pressure gauge.
5. Turn the power on at the switch and turn on gas. **Warning:** There are 230V AC live supplies inside the heater.
6. If remote controllers are fitted, turn the controller on, select the maximum delivery temperature and open ALL available hot water outlets. If remote controllers are not fitted, simply open all available hot water outlets. (CAUTION: Ensure building occupants do not have access to hot water outlets during this procedure).
7. The gas pressure check must be carried out with all other appliances on the same main operating at maximum capacity to ensure that there is sufficient gas pressure.
8. With all appliances on the same main operating at high fire check the pressure at the test point on the inlet to the gas valve. The pressure must be within the local defined limits for the type of gas that is being used. If the pressure is lower, the gas supply is inadequate and the water heater will not operate to specification. Check gas meter, regulator and pipe work for correct operation/sizing and rectify as required. Note that the gas regulator on the appliance is electronically controlled and factory pre-set. Under normal circumstances it does not need adjustment during installation.

UK: the gas pressure must be at least **20 mbar** and no more than **21 mbar** for G20 Natural Gas as used in UK. For G31 Propane as used in the UK the pressure must be at least **34.5 mbar** and no more than **37 mbar**.
9. Close hot water outlets.
10. Inspect and clean the strainer and the filter located on the cold water inlet pipe. This procedure may need to be repeated to ensure the strainer remains clear.
11. If temperature controllers are fitted, it is necessary to test their operation through the complete range of functions.
12. Confirm the hot water delivery temperature using a thermometer. If controllers are fitted, compare the measured value to the set point.
13. After testing is completed, explain to the user the functions and operation of the water heater and temperature controllers.

GAS PRESSURE SETTING

The working gas pressure on the water heater is electronically controlled and factory set. Under normal circumstances it **does not require adjustment during installation**. The pressure should be checked when the unit is installed and each time it is serviced to ensure that it is correct.

Contact Rinnai before attempting to alter the gas pressure if you are unsure of what to do. Incorrect adjustment can void the warranty.

1. Turn 'OFF' the gas supply.
2. Turn 'OFF' 230V power supply.
3. Remove the front cover from the appliance.
4. Check gas type switches no.1 and no.2 of Dip SW2 are in the correct position for the type of gas used. See Fig. 1

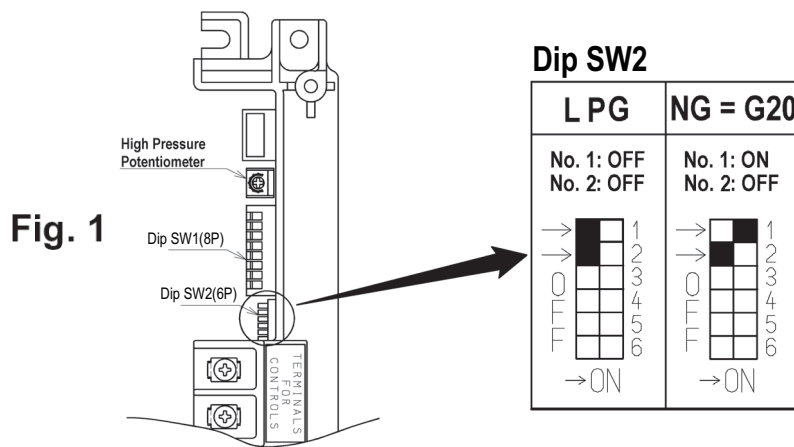

5. Attach pressure gauge to burner test point. (Fig. 2)

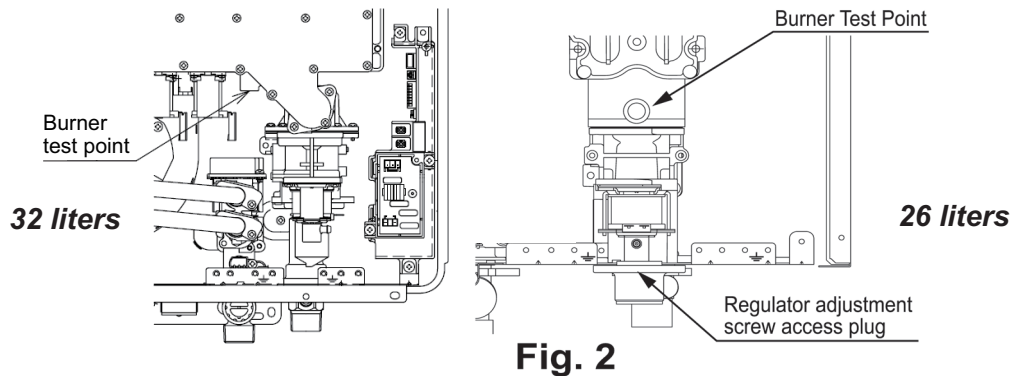

6. Turn 'ON' the gas supply.
7. Turn 'ON' 230V power supply.
8. If remote controllers are fitted, turn the unit 'ON' at the controller and select a maximum delivery temperature.
9. Open a hot water tap fully. (**CAUTION: Ensure building occupants do not have access to hot water outlets during this procedure.**) Wait for the unit to light.



* Simply changing the position of the dip switches will not convert the unit from one gas type to the other. The conversion procedure requires a change of injector manifold. Contact Rinnai or your supplier.

GAS PRESSURE SETTING

10. Set the Rinnai to '**Forced Low**' combustion by setting No.7 switch of Dip SW1 to 'ON'. (Fig. 3)

11. Check the burner test point operating pressure.

LOW	GAS	HD50e	HD70e	26i HD50i	HD70i
NG	G20	1.29	1.83	1.75	1.86
LPG	G31	2.21	2.34	2.36	2.22
<i>(pressures in mbar)</i>					

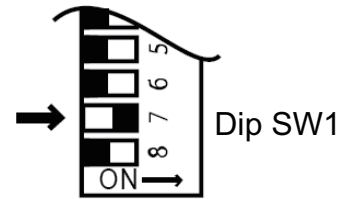

Fig. 3

12. Remove rubber access plug and adjust the regulator screw on the modulating valve (Fig. 4) as required to the pressure above. Replace rubber access plug and seal it shut.

13. Set the Rinnai to '**Forced High**' combustion by setting No.7 and No.8 switches to 'ON' (Fig.5). Ensure maximum water flow.

14. Check the burner test point pressure.

MAX	GAS	HD50e	HD70e	26i HD50i	HD70i
NG	G20	6.81	7.95	9.35	7.95
LPG	G31	11.2	9.25	11.1	9.25
<i>(pressures in mbar)</i>					

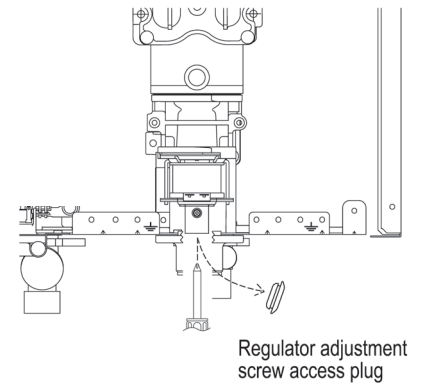

Fig. 4



Fig. 5

15. Adjust the **High Pressure Potentiometer** on the Printed Circuit Board Dip SW1 (Fig. 6) to the pressure shown above. The potentiometer is very sensitive, turn no more than a few degrees at a time; then let the pressure settle down before turning it more.

16. **IMPORTANT:** Set switch No.7 and No.8 of Dip SW1 to 'OFF' to return the appliance to '**Normal**' combustion.

17. Close hot water tap and turn 'OFF' the gas supply and 230V power supply.

18. Remove pressure gauge and replace sealing screw. Turn 'ON' the gas supply and power.

19. Operate unit and check gas leaks.

20. Replace the front cover of the appliance.

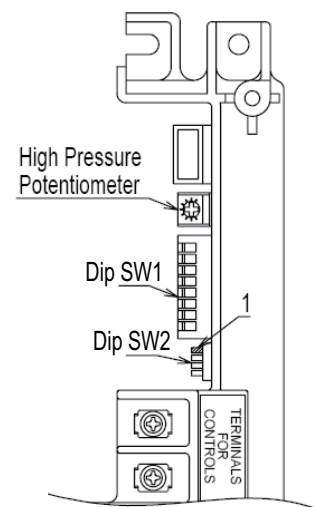
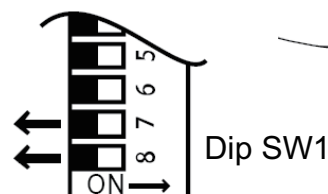

Fig. 6



DIP SWITCH SETTING

Dip Switches Explained

OFF	ON	Dip SW1	
<input type="checkbox"/>	<input type="checkbox"/>	1	- Model Choice
<input type="checkbox"/>	<input type="checkbox"/>	2	- Temperature
<input type="checkbox"/>	<input type="checkbox"/>	3	- Temperature
<input type="checkbox"/>	<input type="checkbox"/>	4	- Temperature
<input type="checkbox"/>	<input type="checkbox"/>	5	- Temperature
<input type="checkbox"/>	<input type="checkbox"/>	6	- Warm Water Switch
<input type="checkbox"/>	<input type="checkbox"/>	7	- Forced Combustion
<input type="checkbox"/>	<input type="checkbox"/>	8	- Forced Combustion

OFF	ON	Dip SW2	
<input type="checkbox"/>	<input type="checkbox"/>	1	- Gas Type
<input type="checkbox"/>	<input type="checkbox"/>	2	- Gas Type
<input type="checkbox"/>	<input type="checkbox"/>	3	- Model Choice
<input type="checkbox"/>	<input type="checkbox"/>	4	- Model Choice
<input type="checkbox"/>	<input type="checkbox"/>	5	- Commercial Setting
<input type="checkbox"/>	<input type="checkbox"/>	6	- Not in use (OFF)

Switch Positions Explained

LEGEND:

Black Section indicates position of switch:



WARM WATER SWITCH

If activated reduces the min flowrate to light

OFF ON Dip SW1 Rinnai when inlet water temperature is close to setpoint temperature

OFF = +3°C (default setting)

ON = off when outgoing temp +6°C

COMMERCIAL SETTING

OFF ON Dip SW2 OFF = No Autoreset
ON = Autoreset

FORCED COMBUSTION

NORMAL

OFF	ON	Dip SW1	
<input checked="" type="checkbox"/>	<input type="checkbox"/>	7	off
<input type="checkbox"/>	<input checked="" type="checkbox"/>	8	off

FORCED LOW

OFF	ON	Dip SW1	
<input type="checkbox"/>	<input checked="" type="checkbox"/>	7	on
<input checked="" type="checkbox"/>	<input type="checkbox"/>	8	off

FORCED HIGH

OFF	ON	Dip SW1	
<input type="checkbox"/>	<input checked="" type="checkbox"/>	7	on
<input type="checkbox"/>	<input type="checkbox"/>	8	on

GAS TYPE

LPG

OFF	ON	Dip SW2	
<input checked="" type="checkbox"/>	<input type="checkbox"/>	1	off
<input type="checkbox"/>	<input checked="" type="checkbox"/>	2	off

NATURAL GAS

OFF	ON	Dip SW2	
<input type="checkbox"/>	<input checked="" type="checkbox"/>	1	on
<input checked="" type="checkbox"/>	<input type="checkbox"/>	2	off

NOT IN USE

Switch No.6 of Dip SW2 is always "off" position

OFF	ON	Dip SW2	
<input checked="" type="checkbox"/>	<input type="checkbox"/>	6	

MODEL CHOICE

HD70e

OFF	ON	Dip SW1	
<input checked="" type="checkbox"/>	<input type="checkbox"/>	1	off

OFF	ON	Dip SW2	
<input checked="" type="checkbox"/>	<input type="checkbox"/>	3	off
<input type="checkbox"/>	<input checked="" type="checkbox"/>	4	off

HD70i + Long Flue

OFF	ON	Dip SW1	
<input checked="" type="checkbox"/>	<input type="checkbox"/>	1	off

OFF	ON	Dip SW2	
<input type="checkbox"/>	<input checked="" type="checkbox"/>	3	on
<input checked="" type="checkbox"/>	<input type="checkbox"/>	4	off

HD70i + Short Flue

OFF	ON	Dip SW1(Factory setting)	
<input type="checkbox"/>	<input checked="" type="checkbox"/>	1	on

OFF	ON	Dip SW2	
<input type="checkbox"/>	<input checked="" type="checkbox"/>	3	on
<input checked="" type="checkbox"/>	<input type="checkbox"/>	4	off

HD50e

OFF	ON	Dip SW1	
<input type="checkbox"/>	<input checked="" type="checkbox"/>	1	on

OFF	ON	Dip SW2	
<input checked="" type="checkbox"/>	<input type="checkbox"/>	3	off
<input type="checkbox"/>	<input checked="" type="checkbox"/>	4	on

26i / HD50i + Long Flue

OFF	ON	Dip SW1	
<input checked="" type="checkbox"/>	<input type="checkbox"/>	1	off

OFF	ON	Dip SW2	
<input type="checkbox"/>	<input checked="" type="checkbox"/>	3	on
<input type="checkbox"/>	<input checked="" type="checkbox"/>	4	on

26i / HD50i + Short Flue

OFF	ON	Dip SW1(Factory setting)	
<input type="checkbox"/>	<input checked="" type="checkbox"/>	1	on

OFF	ON	Dip SW2	
<input type="checkbox"/>	<input checked="" type="checkbox"/>	3	on
<input type="checkbox"/>	<input checked="" type="checkbox"/>	4	on

DIP SWITCH SETTING

26i - HD50e - HD50i - HD70e - HD70i

Temperatures - with or without remotes connected

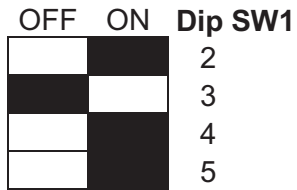

40°C

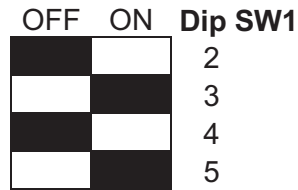

42°C

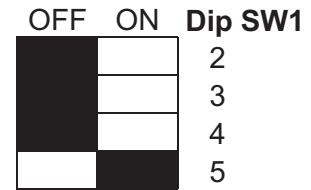

50°C

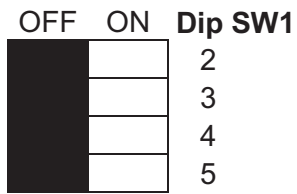

55°C

(Factory Setting for:
26i)

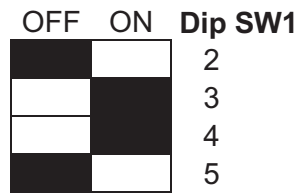

60°C

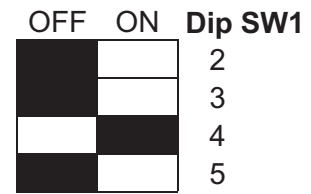

65°C

(Factory Setting for:
70e - 70i - 50e - 50i)

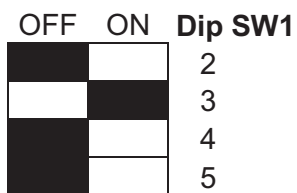

75°C

NOTE: Bypass valve automatically closes if appliance is set at temperatures of 60°C or higher.

Temperatures - without remotes connected

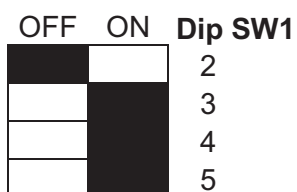

85°C

DIMENSIONS

HD70e

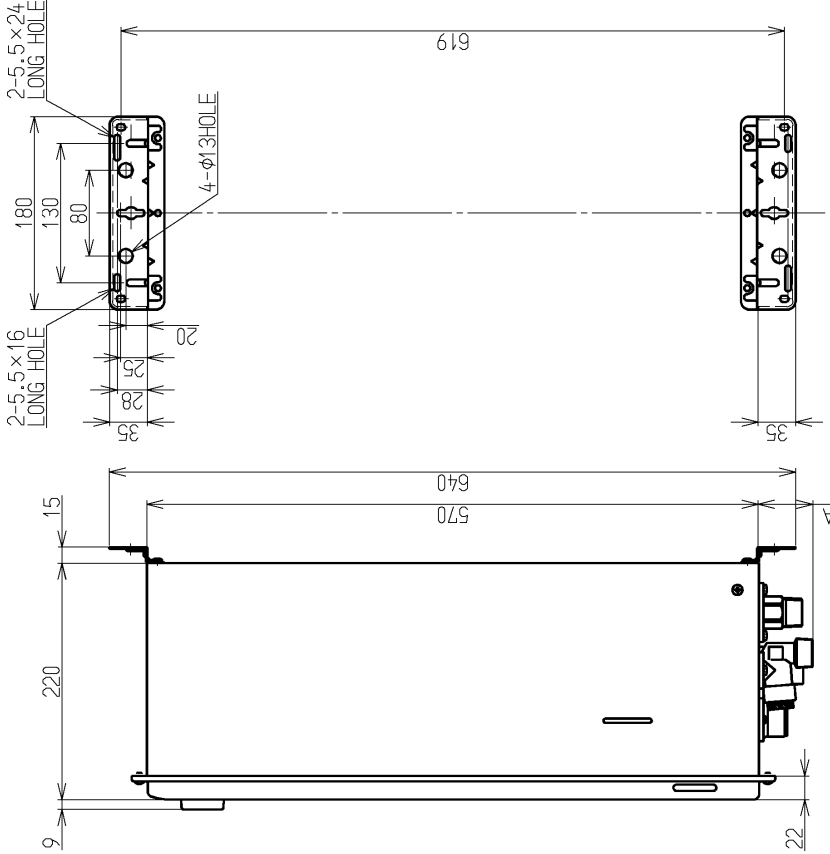

(mm)

	A DIMENSION
GAS	41
COLD	51
HOT	42
ELEC	27

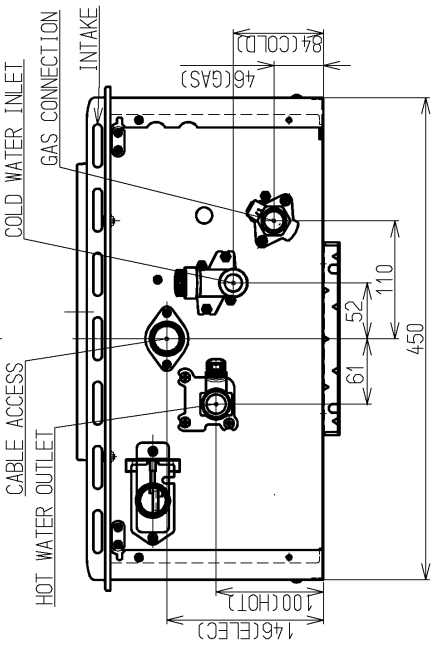
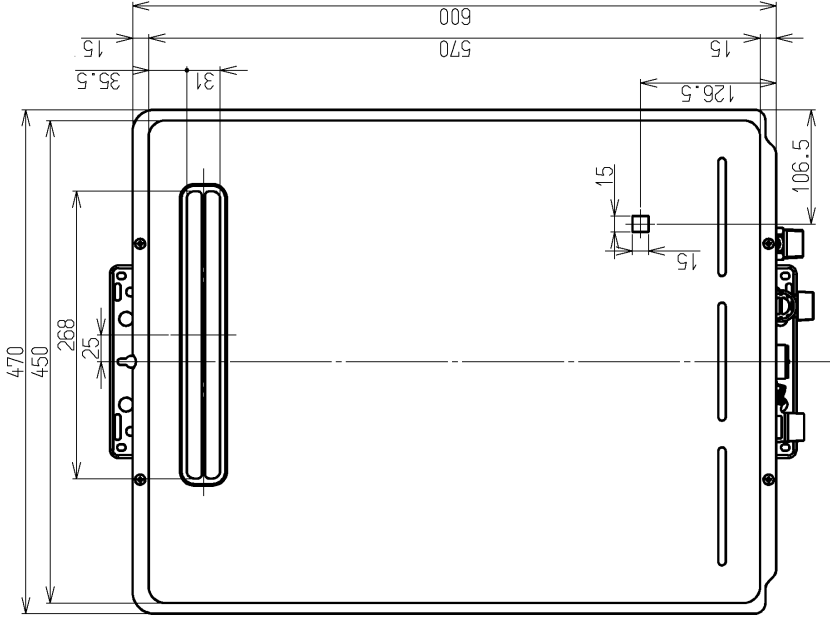

DIMENSIONS

HD70i

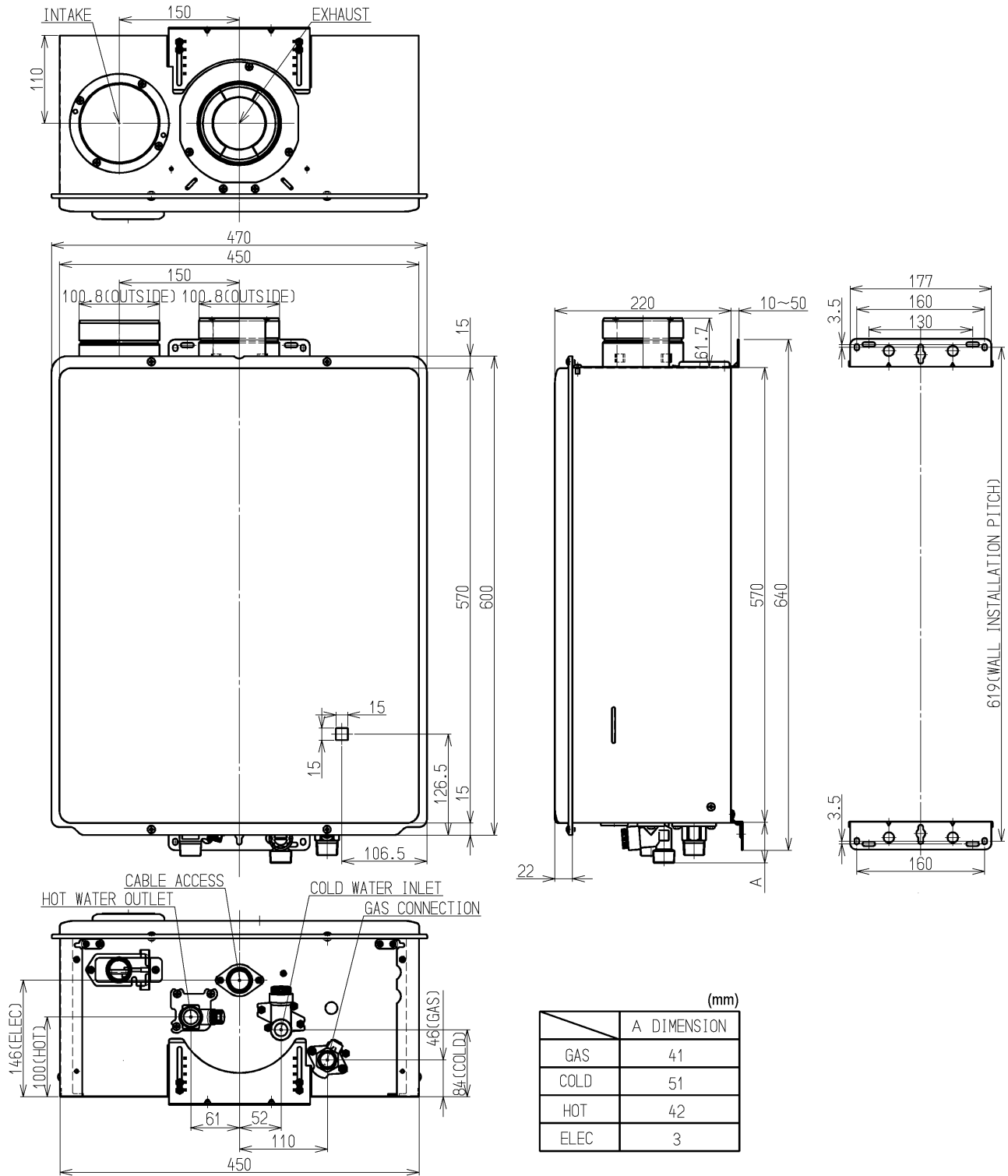

DIMENSIONS

HD50e

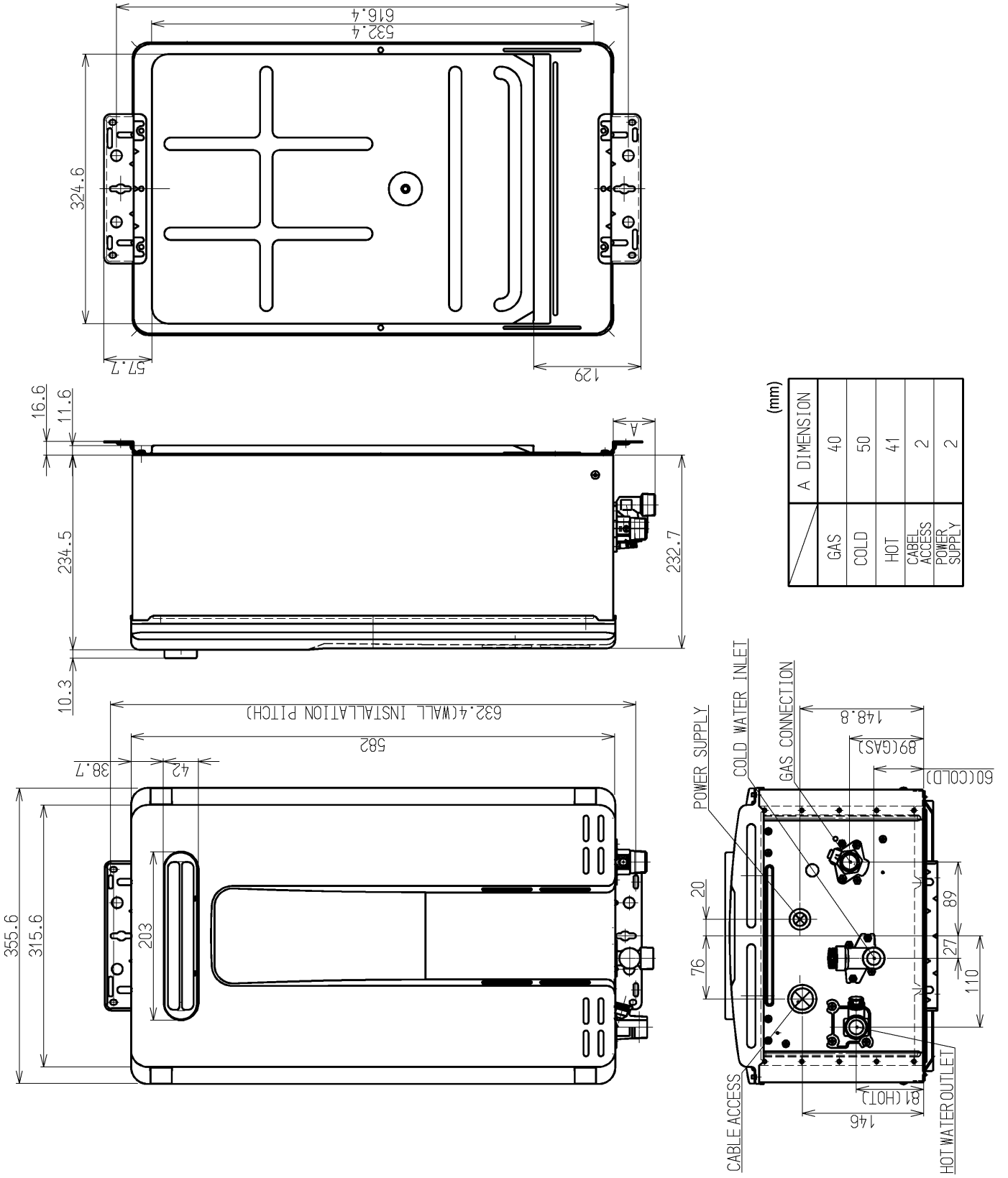

DIMENSIONS

26i - HD50i

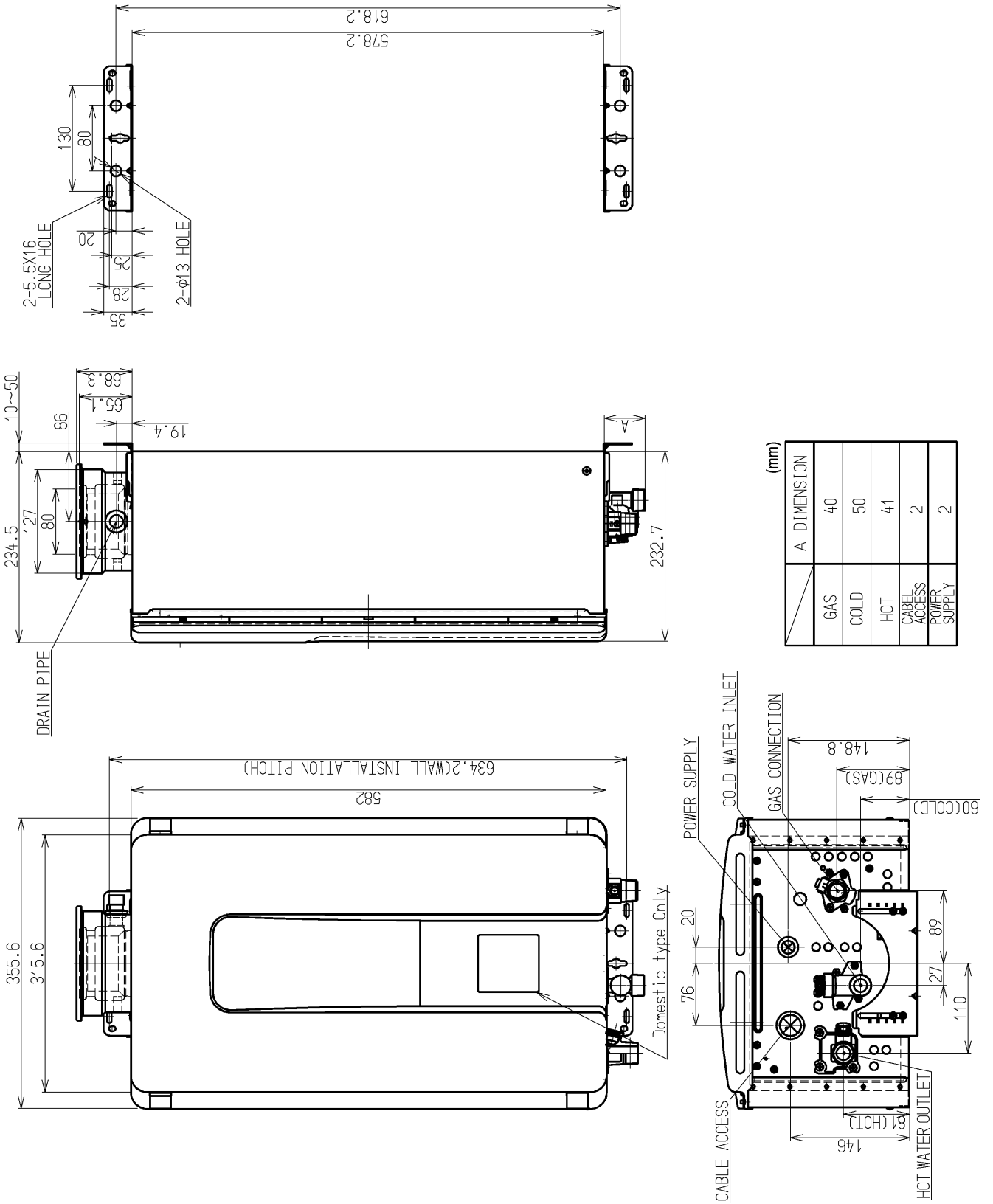

TECHNICAL DETAILS

Model	HD50e	26i - HD50i	Unit
Installation	External	Internal	
G20 Nat Gas Press Low / High	1.29 / 6.81	1.75 / 9.35	mbar
G31 Propane Press Low / High	2.21 / 11.2	2.36 / 11.1	mbar
Flue System	Direct Forced Exhaust	Forced Room Sealed	
Temp. Range Controllers	37-46,48,50,55, (HD:60,65,75)	37-46,48,50,55, (HD:60,65,75)	°C
Temp. via dip switches	40, 42, 50, 55, 60, 65, 75, 85	40, 42, 50, 55, 60, 65, 75, 85	°C
Ignition	Direct Electronic Ignition		
Gas Consumption & Capacities min conditions	H _i = net calorific value H _s = gross calorific value		
G20 Nat Gas: Input Q _m : Hi/Hs Useful output P _m	3.93/4.36 3.49	3.93/4.36 3.49	kW
G20 Nat Gas flow normal operating conditions V _m	0.42	0.42	m ³ /hr
G31 Input Q _m : Hi/Hs Useful output P _m	4.01/4.36 3.49	4.01/4.36 3.49	kW
G31 flow normal operating conditions M _m	0.31	0.31	kg./hr
Gas Consumption & Capacities nominal condit.	H _i = net calorific value H _s = gross calorific value		
G20 Nat Gas: Input Q _n : Hi/Hs Useful output P _n	49.8/55.3 45.9	48.6/54.0 44.8	kW
G20 Nat Gas flow ref. conditions V _r	5.27	5.14	m ³ /hr
G31 Input Q _n : Hi/Hs Useful output P _n	50.9/55.3 45.9	49.7/54.0 44.8	kW
G31 flow normal operating conditions M _n	3.95	3.86	kg./hr
Country of destination	GB,IE		
Gas category and pressure	I2H G20-20mbar / I3P G31-37mbar		
Type	A3	C13,C33	
Max Flow	32	32	L/min
Min Operation Flow	ON=2,4 * / OFF=1,7 *	ON=2,4 * / OFF=1,7 *	L/min
Operating Water Pressure (P _w)	1,4 * - 10	1,4 * - 10	Bar
Power Supply	230V/50Hz		
Electric Consumption (1 remote)	50	66	W
Electric Consumption standby (1 remote)	2	2	W
Electric Consumption (antifrost)	100	100	W
Ignition safety time T _{SAmax}	4.2	4.2	Sec.
Weight	23	24	kg
IPx Protection	IPX4	-	-
NOx at Max Input GCV O2 0% G20 / G31	-	70 / 70	mg/kWh
Load Profile	-	XL	
Water Heating Efficiency η _{wh}	-	82.3	%
Daily Fuel Consumption Q _{fuel}	-	24.133	kWh
Daily Electrical Consumption Q _{elec}	-	0.063	kWh
Sound Power Level L _{WA}	-	64	dB

* Minimum operation flow based on temperature setpoint and inlet conditions.

TECHNICAL DETAILS

Model	HD70e	HD70i	Unit
Installation	External	Internal	
G20 Nat Gas Press Low / High	1.83 / 7.95	1.86 / 7.95	mbar
G31 Propane Press Low / High	2.34/ 9.25	2.22 / 9.25	mbar
Flue System	Direct Forced Exhaust	Forced Room Sealed	
Temp. Range Controllers	37-46,48,50,55, (HD:60,65,75)	37-46,48,50,55, (HD:60,65,75)	°C
Temp. via dip switches	40, 42, 50, 55, 60, 65, 75, 85	40, 42, 50, 55, 60, 65, 75, 85	°C
Ignition	Direct Electronic Ignition		
Gas Consumption & Capacities min conditions	H _i = net calorific value H _s = gross calorific value		
G20 Nat Gas: Input Q _m : Hi/Hs Useful output P _m	5.00/5.55 4.46	5.00/5.55 4.46	kW
G20 Nat Gas flow normal operating conditions V _m	0.53	0.53	m ³ /hr
G31 Input Q _m : Hi/Hs Useful output P _m	5.20/5.65 4.62	5.00/5.43 4.46	kW
G31 flow normal operating conditions M _m	0.40	0.39	kg./hr
Gas Consumption & Capacities nominal condit.	H _i = net calorific value H _s = gross calorific value		
G20 Nat Gas: Input Q _n : Hi/Hs Useful output P _n	62.3/69.0 57.0	62.3/69.0 57.0	kW
G20 Nat Gas flow ref. conditions V _r	6.59	6.59	m ³ /hr
G31 Input Q _n : Hi/Hs Useful output P _n	62.3/67.7 57.0	62.3/67.7 57.0	kW
G31 flow normal operating conditions M _n	4.84	4.84	kg./hr
Country of destination	GB,IE		
Gas category and pressure	I2H G20-20mbar / I3P G31-37mbar		
Type	A3	C13,C33	
Max Flow	37	37	L/min
Min Operation Flow	ON=2,4 * / OFF=1,7 *	ON=2,4 * / OFF=1,7 *	L/min
Operating Water Pressure (P _w)	2,0 * - 10	2,0 * - 10	Bar
Power Supply	230V/50Hz		
Electric Consumption (1 remote)	67	99	W
Electric Consumption standby (1 remote)	2	2	W
Electric Consumption (antifrost)	100	100	W
Ignition safety time T _{SAmax}	4.5	4.5	Sec.
Weight	25	25	kg
IPx Protection	IPX4	-	-
NOx at Max Input GCV O2 0% G20 / G31	55 / 70	-	mg/kWh
Load Profile	XL	-	
Water Heating Efficiency η _{wh}	83.2	-	%
Daily Fuel Consumption Q _{fuel}	23.889	-	kWh
Daily Electrical Consumption Q _{elec}	0.048	-	kWh
Sound Power Level L _{WA}	-	-	dB

* Minimum operation flow based on temperature setpoint and inlet conditions.

FLOW CHART

26i - HD50e - HD50i - HD70e - HD70i

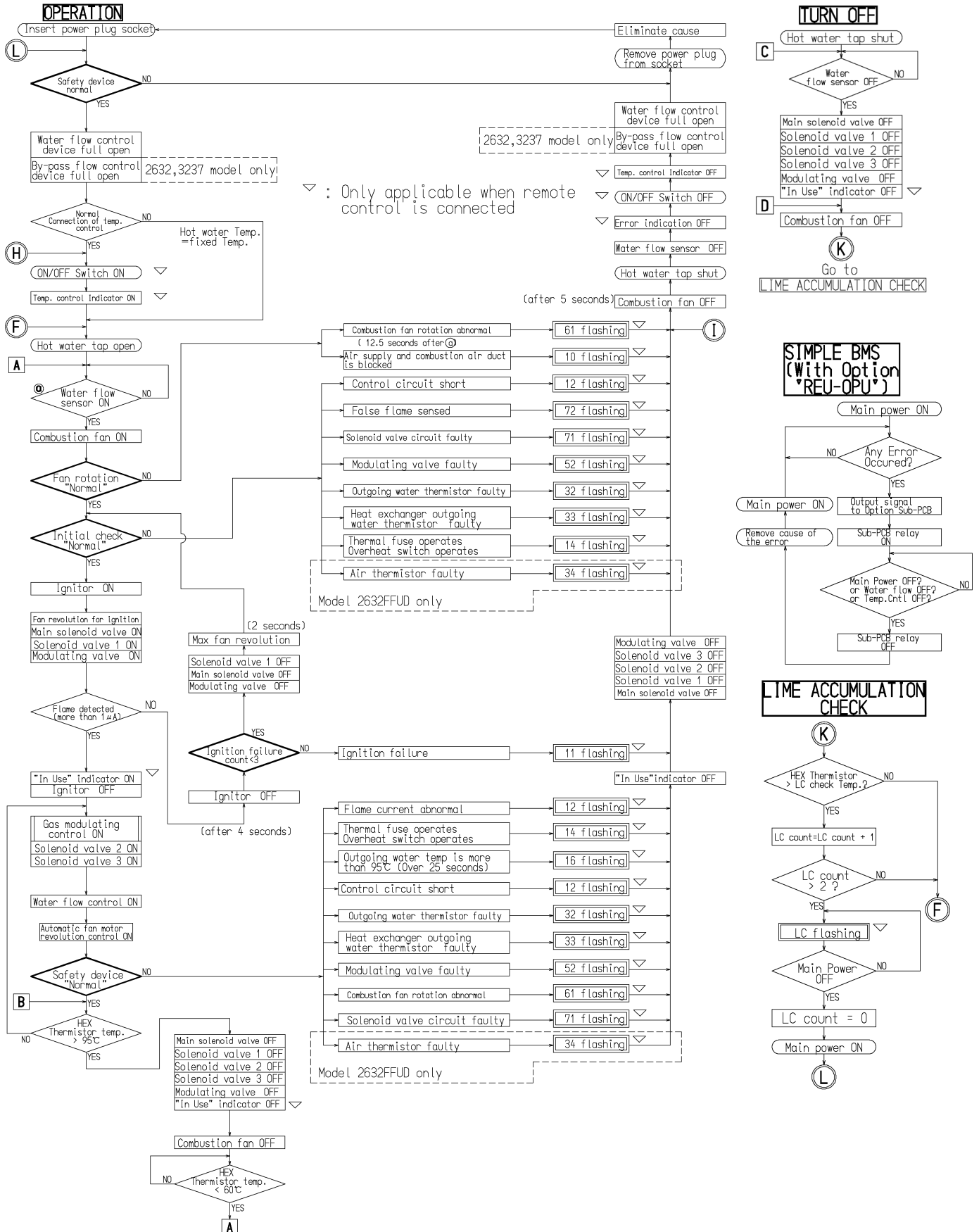

WIRING DIAGRAM

HD70e - HD70i

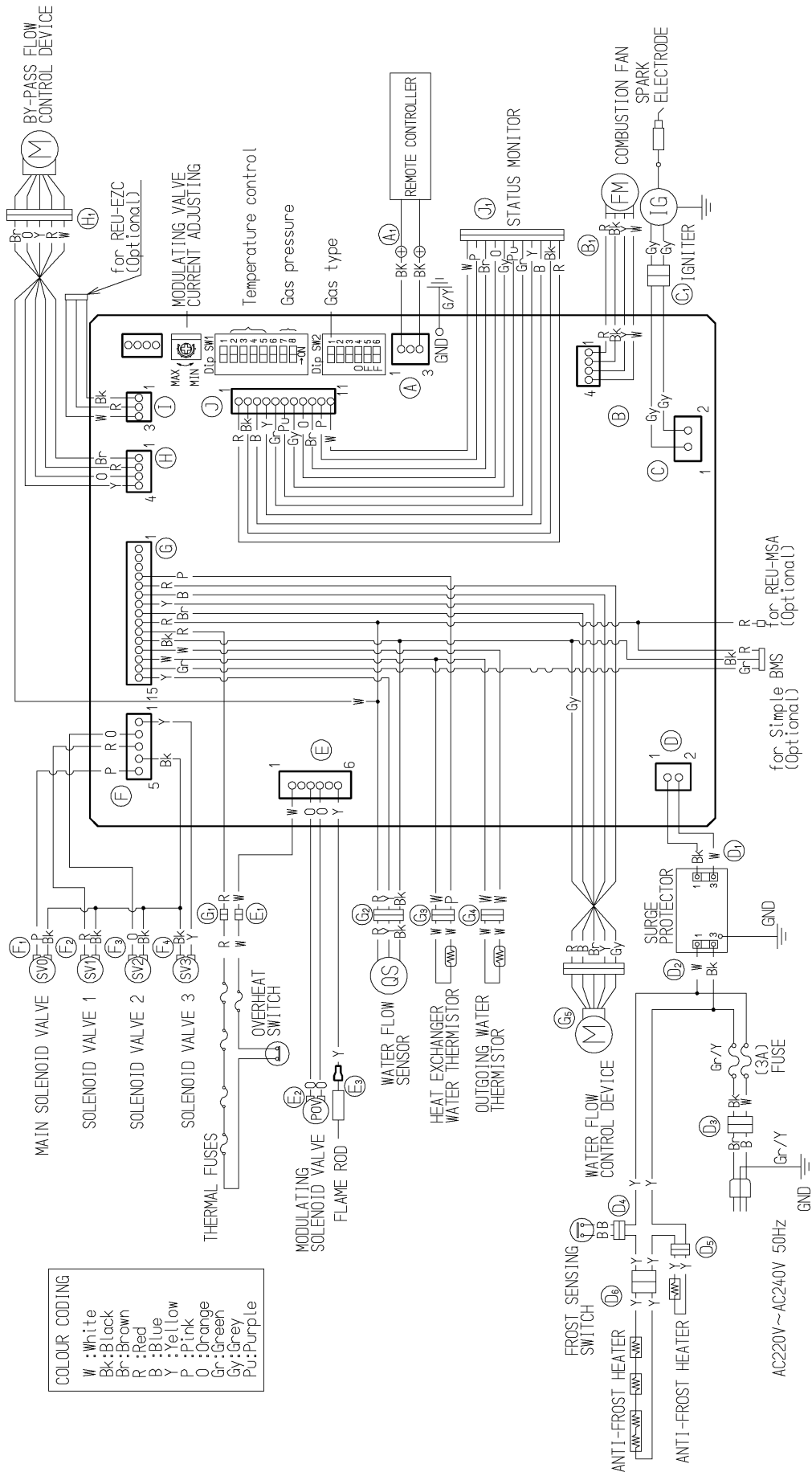

DIAGNOSTIC POINTS

26i - HD50e - HD50i

HD70e - HD70i

FLOW CHART No.	COMPONENT	MEASUREMENT POINT		NORMAL VALUE	A NOTE
		CN	WIRE COLOUR		
①	SURGE PROTECTOR	D ₁	W-Bk	AC198~253V	
②	WATER FLOW CONTROL DEVICE	G ₆	R-B	DC11~13V	OPERATE ELECTRICITY
			Gy-0	DC11~13V	CONTROL ELECTRICITY
①⑦	WATER FLOW CONTROL DEVICE	G ₅	Gy-Y	BELOW DC1V(LIMITER ON) DC4~6V(LIMITER OFF)	FULL OPEN POSITION
			Gy-Br	BELOW DC1V(LIMITER ON) DC4~6V(LIMITER OFF)	FULL CLOSE POSITION
③	BY-PASS FLOW CONTROL DEVICE	H ₁	Br-W	DC12V(OPERATING DC2~6V)	
			O-W		
④	REMOTE CONTROL	A ₁	Y-W	15~35Ω	
			R-W		
⑤	WATER FLOW SENSOR	G ₂	Bk-Bk	DC11~13V	
			R-Bk		
⑥	COMBUSTION FAN	B ₁	Y-Bk GND	DC4~7V(PULSE 17~460Hz)	
			R-Bk		
⑦	FLAME ROD	E ₃	Y-Bk	DC6~45V	
			W-Bk GND		
⑧	MODULATING VALVE	E ₂	Y-BODY EARTH	DC6~45V (33~400Hz)	AFTER IGNITION
			Y-FLAME ROD		
⑨	OUTGOING THERMISTOR	G ₄	P-P	OVER DC1 μA	FLAME CONDITION
			W-W		
⑩	HEAT EXCHANGER OUTGOING THERMISTOR	G ₃	W-W	DC2~15V	
			W-W		
⑪	AIR TEMPERATURE THERMISTOR	G ₅	W-W	67~81Ω	
			W-W		
⑫	THERMAL FUSE	G ₁	R-R	BELOW 1Ω	
			E ₁		
⑬	IGNITER	C	B-B	AC207~264V	
⑭	MAIN SOLENOID VALVE	F ₁	P-Bk	DC11~13V	
			Y-Bk		
⑮	SOLENOID VALVE 1	F ₂	B-Bk	37~43Ω	
			Y-Bk		
⑯	SOLENOID VALVE 2	F ₃	B-Bk	DC11~13V	
			Br-Bk		
⑰	SOLENOID VALVE 3	F ₄	Br-Bk	37~43Ω	
			Y-Bk		
⑱	SOLENOID VALVE 1	F ₂	R-Bk	DC11~13V	
			O-Bk		
⑲	SOLENOID VALVE 2	F ₃	O-Bk	37~43Ω	
			Y-Bk		
⑳	SOLENOID VALVE 3	F ₄	Y-Bk	DC11~13V	
			Y-Bk		

WATER FLOW CHARACTERISTICS

26i - HD50e - HD50i - HD70e - HD70i

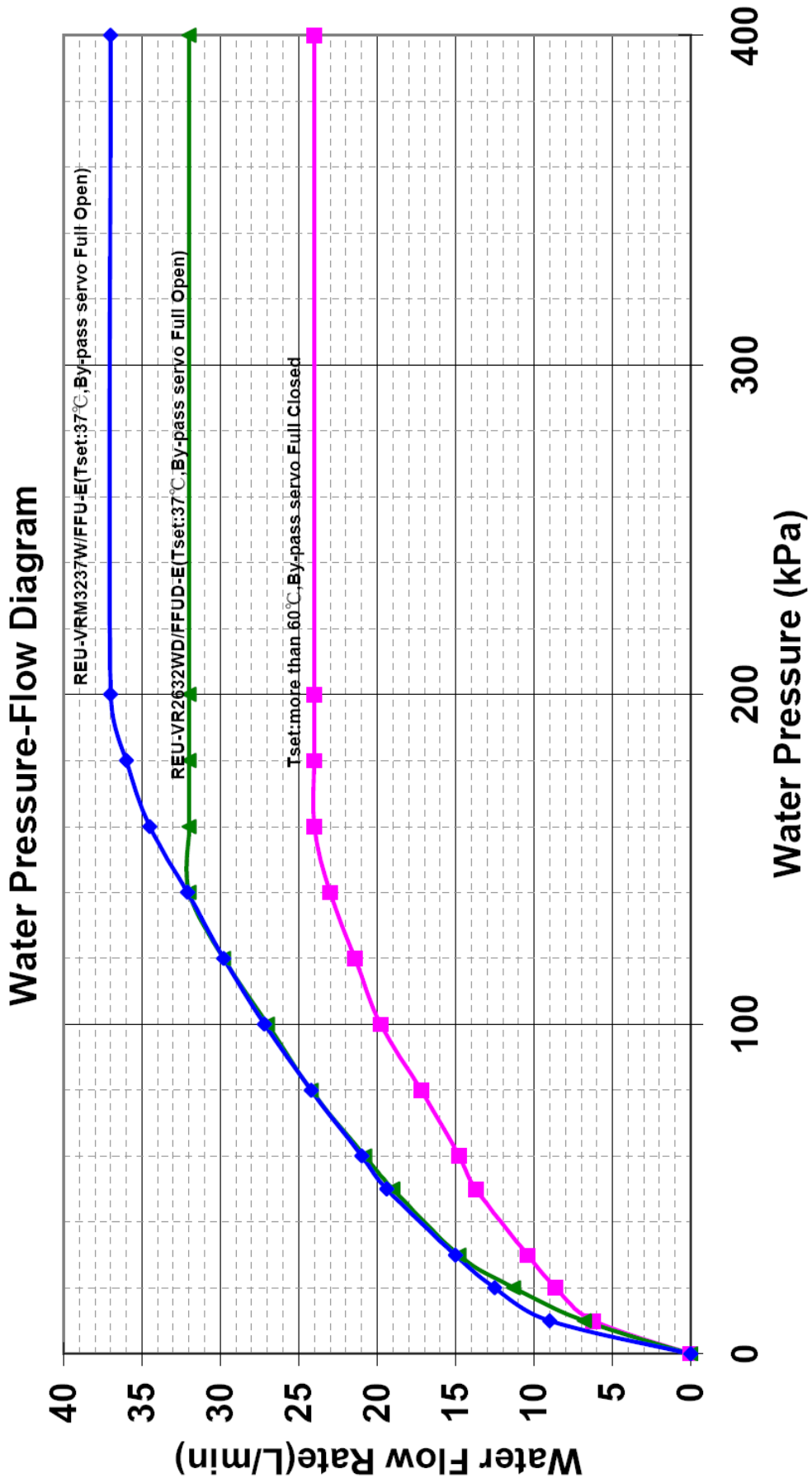

LETTER OF COMPLIANCE

Conformity Declaration

We, Rinnai Corporation, Nagoya herewith confirm that the following models:

REU-VRM3237W-E
REU-VRM3237WHD-E
REU-VRM3237FFU-E
REU-VRM3237FFUHD-E

REU-VR2632WD-E
REU-VR2632WDHD-E
REU-VR2632FFUD-E
REU-VR2632FFUDHD-E

comply with the directives mentioned below:

2009/142/EC Gas Directive
73/23/EEG Low Voltage Directive
89/336/EEG EMC Directive

The following harmonized standard has been used:

Gas-fired instantaneous water heaters for the production of domestic hot water, fitted with atmospheric burners (EN26)

Nagoya, 24th August Rinnai Corporation



Yuzo Yoshida,
Managing Executive Officer
& General Manager

CE CERTIFICATE

Technigas

Module B

ECTYPE EXAMINATION CERTIFICATE

Annex II Paragraph I directive 2009/142/EC



Certificate number : E1061/5498 Rev1
ID number : 0461BS0903
Date of issue : 26/10/2007
Revised: 23/08/2010

Fabricant : RINNAI Corporation
Manufacture : 2-26 Fukuzumi-Cho
Fabrikant : Nakagawa-Ku, Nagoya, Japan

Marque commerc. : RINNAI
Trade mark
Handelsmerk

Type : REU-VM3237W-E(Infinity 32e) - REU-VRM3237W-E(Infinity 32e)
Model : REU-VM3237WHD-E(HD70e) - REU-VRM3237WHD-E(HD70e)
Type

Genre d'appareil : INSTANTANEOUS WATER HEATER
Kind of product
Soort toestel

Type d'appareil : A₃ - Only for outdoor installation
Appliance type
Type toestel

Countries of destination, appliance categories :

AL-AT-BE BG CH CY-CZ- DE- DK- EE- ES- FI- FR-GB-GR- HU- HR-IE- IS - IT- LT- LU- LV-
MK- MT- NL-NO- PL-PT- RO- SE- SI- SK- TR

I2H // I2L // I2E // I2E(S) // I2Esi // I2HM // I3B/P // I3P

G20-20 mbar // G25-25 mbar // G20/G25-20/25 mbar // G30-28/30 mbar
G30-30 mbar // G30-37 mbar // G31-30 mbar // G31-37 mbar // G31-50 mbar
G230-20mbar

Normative references : EN 26

This document cancels and replaces the previous one of : 26/10/2007

DIRECTOR
K DE WIT

n° 199-PROD



TGP-08-14
2002-04-12

TECHNIGAS - Rodestraat, 125 - B-1630 Linkebeek
Phone +32 2 383 02 00 - Fax +32 2 380 87 04
e-mail : technigas@technigas.be - website : www.technigas.be

CE CERTIFICATE

Technig 

Module B

EC TYPE EXAMINATION CERTIFICATE

Annex II Paragraph I directive 2009/142/EC



Certificate number : E1060/5498 Rev1 *Date of issue* : 26/10/2007
ID number : 0461BS0903 *Revised*: 23/08/2010

Fabricant : RINNAI Corporation
Manufacture : 2-26 Fukuzumi-Cho
Fabrikant : Nakagawa-Ku, Nagoya , Japan

Marque commerc. : RINNAI
Trade mark
Handelsmerk

Type : REU-VM3237-FFU-E(Infinity 32i) – REU-VRM3237FFU-E(Infinity 32i)
Model : REU-VM3237-FFUHD-E(HD70i) – REU-VRM3237FFUHD-E(HD70i)
Type

Genre d'appareil : INSTANTANEOUS WATER HEATER
Kind of product
Soort toestel

Type d'appareil : C13/ C33
Appliance type
Type toestel

Countries of destination, appliance categories :
AL-AT-BE-BG- CH- CY- CZ- DE- DK- EE- ES- FI- FR-GB-GR- HU-HR-IE- IS - IT- LT- LU- LV- MK- MT-
NL-NO- PL-PT- RO- SE- SI- SK- TR

I2H // I2L // I2E // I2E(S) // I2Esi // I2HM // I3B/P // I3P // I3R

G20-20 mbar // G25-25 mbar // G20/G25-20/25 mbar // G30-28/30 mbar
G30-30 mbar // G30-37 mbar // G31-30 mbar // G31-37 mbar // G31-50 mbar
G230-20mbar

Normative references : EN 26

This document cancels and replaces the previous one of : 26/10/2007

DIRECTOR
K DE WIT

n° 199-PROD



TGP-08-14
2002-04-12

TECHNIGAS - Rodestraat, 125 - B-1630 Linkebeek
Phone +32 2 383 02 00 - Fax +32 2 380 87 04
e-mail : technigas@technigas.be - website : www.technigas.be

CE CERTIFICATE

Technigas

Module B

EC TYPE EXAMINATION CERTIFICATE

Annex II Paragraph 1 directive 2009/142/EC



Certificate number : E0716/5360 Rev.5
ID number : 0461BO0739
Date of issue : 28/07/2003
Revised : 23/08/2010

Fabricant : RINNAI Corporation
Manufacture : Fukuzumi-Cho 2-26
Fabrikant : J - Nakagawa, Nagoya

Marque commerc. : RINNAI
Trade mark
Handelsmerk

Type : REU-V2632 FFU-E(Infinity 26i)(*
Model : HD 50i (HD50i)(* - REU-VR2632FFUD-E(Infinity 26i)
Type : REU-VR2632FFUDHD-E(HD50i)

Genre d'appareil : INSTANTANEOUS WATER HEATER
Kind of product
Soort toestel

Type d'appareil : B23/ C13/ C33
Appliance type : B23X/ C13X/ C33X
Type toestel

Countries of destination, appliance categories :

AL-AT-BE-BG- CH- CY- CZ- DE- DK- EE- ES- FI- FR-GB-GR- HU-HR-IE- IS - IT- LT- LU- LV- MK- MT- NL-NO- PL-PT- RO- SE- SI- SK- TR

I2H // I2E // I2E(S) // I2Esi // I2HM // I3B/P // I3P // I3R
(*): I2L // I2E // I2E(S) // I2Esi

G20-20 mbar // G30-28/30 mbar G30-30 mbar // G30-37 mbar // G31-30 mbar // G31-37 mbar // G31-50 mbar // G230-20mbar
(*): G25/25 mbar // G20/G25-20/25 mbar

Normative references : EN 26

This document cancels and replaces the previous one of : 18/09/2006

DIRECTOR
K DE WIT

n° 199-PROD



TGP-08-14
2002-04-12

TECHNIGAS - Rodestraat, 125 - B-1630 Linkebeek
Phone +32 2 383 02 00 - Fax +32 2 380 87 04
e-mail : technigas@technigas.be - website : www.technigas.be

CE CERTIFICATE

Technigas

Module B

EC TYPE EXAMINATION CERTIFICATE

Annex II Paragraph I directive 2009/142/EC



Certificate number : E0841/5386 Rev.5
ID number : 0461BP0795
Date of issue : 23/12/2004
Revised: 23/08/2010

Fabricant : RINNAI Corporation
Manufacture : Fukuzumi-Cho 2-26
Fabrikant : JP - Nakagawa, Nagoya

Marque commerc. : RINNAI
Trade mark
Handelsmerk

Type : REU-V2018 W-E - REU-V2632 W-E - REU-VRM1120WD-E(Infinity 11e)
Model : REU-VRM1420WD-E(Infinity 14e) - REU-VRM1720WD-E(Infinity 17e)
Type : REU-VRM2024WD-E(Infinity 20e) - REU-VR2632WD-E(Infinity 26e)
REU-VR2632WDHD-E(HD50e)

Genre d'appareil : INSTANTANEOUS WATER HEATER
Kind of product
Soort toestel

Type d'appareil : A₃ - Only outdoor installation
Appliance type
Type toestel

Countries of destination, appliance categories :
AL-AT-BE-BG- CH- CY- CZ- DE- DK- EE- ES- FI- FR-GB-GR- HU-HR-IE- IS - IT- LT- LU- LV- MK- MT-
NL-NO- PL-PT- RO- SE- SI- SK- TR

I2H // I2L // I2E // I2E(S) // I2Esi // I2HM // I3B/P // I3P

G20-20 mbar // G25-25 mbar // G20/G25-20/25 mbar // G30-28/30 mbar
G30-30 mbar // G30-37 mbar // G31-30 mbar // G31-37 mbar // G31-50 mbar
G230-20mbar (except for REU-V2626W-E /REU-V2018 W-E)

Normative references: EN 26

This document cancels and replaces the previous one of : 06/08/2008

DIRECTOR
K DE WIT

n° 199-PROD



TGP-08-14
2002-04-12

TECHNIGAS - Rodestraat, 125 - B-1630 Linkebeek
Phone +32 2 383 02 00 - Fax +32 2 380 87 04
e-mail : technigas@technigas.be - website : www.technigas.be

COMMISSIONING CHECK LIST

- The water heater is not subject to corrosive compounds in the air.
- The water supply does not contain chemicals or exceeds total hardness that will damage the heat exchanger.
- Clearances from the water heater unit are met.
- Clearances from the vent termination / air intake are met.
- For indoor models, ensure you have used the correct venting products for the model installed and that you have completely followed the venting manufacturer's installation instructions and these installation instructions.
- For indoor models, verify that the vent system does not exceed the maximum length for the number of elbows used.
- Purge the water line of all debris and air by closing the hot isolation valve and opening the cold isolation valve and its drain. **Debris will damage the water heater.** Use a bucket or hose if necessary.
- Ensure that hot and cold water lines are not crossed to the unit and are leak free.
- A manual gas control valve has been placed in the gas line to the water heater.
- Clean the inlet water filter by closing the cold and hot water inlet isolation (shut-off) valves. Put a bucket under the filter at the bottom of the water heater to catch any water that is contained inside the unit. Unscrew the water filter. Rinse the filter to remove any debris. Install the filter and open the isolation valves.
- Check the gas lines and connections for leaks.
- Confirm that the gas inlet pressure is within limits.
- Confirm that the water heater is rated for the gas type supplied.
- Confirm that the electricity is supplied from a 230V AC, 50 Hz power source, is in a properly grounded circuit, and turned on.
- Verify the temperature controller is functioning properly if fitted.
- Verify the system is functioning correctly by connecting your manometer to the gas pressure test port on the water heater. Operate all gas appliances in the home or facility at high fire. The inlet gas pressure at the water heater must not drop below that listed on the rating plate.
- If the water heater is not needed for immediate use, then drain the water from the heat exchanger.
- Install the front panel.
- Explain to the customer the importance of not blocking the vent termination or air intake.
- Explain to the customer the operation of the water heater, safety guidelines, maintenance, and warranty.
- The installation must conform with local codes.
- Inform the consumer if the isolation valves are not installed or if a water softening system is not installed.
- **Leave the entire manual taped to the water heater (indoor models), temperature controller (outdoor models), or give the entire manual directly to the consumer.**

COMMISSIONING SHEET

GAS FIRED CONTINUOUS FLOW WATER HEATER COMMISSIONING CHECKLIST

This Commissioning Checklist is to be completed in full by the competent person who commissioned the water heater as a means of demonstrating compliance with the appropriate Building Regulations and then handed to the customer to keep for future reference

Failure to install and commission according to the manufacturer's instructions and complete this Benchmark Commissioning Checklist will invalidate the warranty. This does not affect the customer's statutory rights.

Customer name:		Telephone number:	
Address:			
Water Heater Make & Model:			
Serial Number:			
Commissioned by (PRINT NAME):		Gas Safe Register Number:	
Company name:		Telephone number:	
Company address:			
		Commissioning date:	
To be completed by the customer on receipt of a Building Regulations Compliance Certificate*:			
Building Regulations Notification Number (if applicable)			
CONTROLS			
Is there a separate temperature control fitted	Yes		No
Have they been explained to the customer	Yes		No
Has the Appliance been set to the required MAX temp.	Yes		No
If NO has the Appliance been set to the required temp.	Yes		No
SYSTEM			
Is there a filter on the incoming mains	Yes		No
Is the system on a secondary return	Yes		No
Has an unvented kit been installed	Yes		No
If yes please record Safety Valve Size and rating	Size	Rating	
Does the discharge pipe comply with current building regulations			Yes
Please record location of Pressure Reducing Valve			
Pressure Reducing Valve Setting			
Expansion Vessel Size			
Expansion Vessel Charge Pressure			
Has the system been installed with a storage vessel	Yes		No
DOMESTIC HOT WATER MODE			
Gas Rate at High Fire	m ³ /hr	ft ³ /hr	
Burner Pressure	Lo	mbar	Hi
Inlet Pressure Dynamic at Hi Fire and all other appliances running	mbar		
Inlet water temp			°C
Water Heater Set Temperature			°C
Maximum Flow Rate Achieved	L/min		
Is the installation in a hard water area (above 150mg/L)	Yes		No
If Yes What Type of Scale Reducer has been Fitted			
Hot Water checked at all outlets	Yes	Temp	°C
FLUEING			
What type of water heater is fitted	Internal	External	
EXTERNAL is the unit mounted fully outside	Yes		No
If NO explain in detail where the appliance is mounted			
INTERNAL does the flueing comply with current standards			
Yes		No	
If the flueing to manufacturers instructions	Yes		No
CONDENSING WATER HEATERS ONLY			
Has the condensate drain has been installed as per manufacturers instructions and/or BS5446/BS6798	Yes		No
FULL INSTALLATION			
Record the following:	At max rate: CO ppm	and	CO/CO ₂ Ratio
	At min. Rate: (where possible) CO ppm	and	CO/CO ₂ Ratio
Does the hot water system fully comply with the appropriate Building Regulations			Yes
The water heater and associated products have been installed and commissioned in accordance with all manufacturers instructions			Yes
The full operation of the water heater and any controls have been demonstrated to and understood by the customer			Yes
The manufacturers literature including Benchmark Checklist and Service Record, has been explained and left with the customer			Yes
Commissioning Engineer's Signature			
Customer's Signature			
(To confirm satisfactory demonstration and receipt of manufacturer's literature)			

*All installations in England and Wales must be notified to Local Authority Building Control (LABC) either directly or through a Competent Persons Scheme. A Building Regulations Compliance Certificate will then be issued to the customer.



SERVICE RECORD

SERVICE RECORD

It is recommended that your heating system is serviced regularly and that the appropriate Service Interval Record is completed.

Service Provider

Before completing the appropriate Service Interval Record below, please ensure you have carried out the service as described in the manufacturer's instructions. Always use the manufacturer's specified spare part when replacing controls.

<table border="1" style="width: 100%; border-collapse: collapse;"> <tr> <td style="width: 70%;">SERVICE 01</td> <td style="width: 30%;">Date:</td> </tr> <tr><td>Engineer name:</td></tr> <tr><td>Company name:</td></tr> <tr><td>Telephone No:</td></tr> <tr><td>Operative ID No:</td></tr> <tr><td>Comments:</td></tr> <tr><td> </td></tr> <tr><td> </td></tr> <tr><td> </td></tr> <tr><td> </td></tr> <tr><td> </td></tr> <tr><td> </td></tr> <tr><td>Signature</td></tr> </table>	SERVICE 01	Date:	Engineer name:	Company name:	Telephone No:	Operative ID No:	Comments:							Signature	<table border="1" style="width: 100%; border-collapse: collapse;"> <tr> <td style="width: 70%;">SERVICE 02</td> <td style="width: 30%;">Date:</td> </tr> <tr><td>Engineer name:</td></tr> <tr><td>Company name:</td></tr> <tr><td>Telephone No:</td></tr> <tr><td>Operative ID No:</td></tr> <tr><td>Comments:</td></tr> <tr><td> </td></tr> <tr><td> </td></tr> <tr><td> </td></tr> <tr><td> </td></tr> <tr><td> </td></tr> <tr><td> </td></tr> <tr><td> </td></tr> <tr><td>Signature</td></tr> </table>	SERVICE 02	Date:	Engineer name:	Company name:	Telephone No:	Operative ID No:	Comments:								Signature	
SERVICE 01	Date:																														
Engineer name:																															
Company name:																															
Telephone No:																															
Operative ID No:																															
Comments:																															
Signature																															
SERVICE 02	Date:																														
Engineer name:																															
Company name:																															
Telephone No:																															
Operative ID No:																															
Comments:																															
Signature																															
<table border="1" style="width: 100%; border-collapse: collapse;"> <tr> <td style="width: 70%;">SERVICE 03</td> <td style="width: 30%;">Date:</td> </tr> <tr><td>Engineer name:</td></tr> <tr><td>Company name:</td></tr> <tr><td>Telephone No:</td></tr> <tr><td>Operative ID No:</td></tr> <tr><td>Comments:</td></tr> <tr><td> </td></tr> <tr><td> </td></tr> <tr><td> </td></tr> <tr><td> </td></tr> <tr><td> </td></tr> <tr><td> </td></tr> <tr><td> </td></tr> <tr><td>Signature</td></tr> </table>	SERVICE 03	Date:	Engineer name:	Company name:	Telephone No:	Operative ID No:	Comments:								Signature	<table border="1" style="width: 100%; border-collapse: collapse;"> <tr> <td style="width: 70%;">SERVICE 04</td> <td style="width: 30%;">Date:</td> </tr> <tr><td>Engineer name:</td></tr> <tr><td>Company name:</td></tr> <tr><td>Telephone No:</td></tr> <tr><td>Operative ID No:</td></tr> <tr><td>Comments:</td></tr> <tr><td> </td></tr> <tr><td> </td></tr> <tr><td> </td></tr> <tr><td> </td></tr> <tr><td> </td></tr> <tr><td> </td></tr> <tr><td> </td></tr> <tr><td>Signature</td></tr> </table>	SERVICE 04	Date:	Engineer name:	Company name:	Telephone No:	Operative ID No:	Comments:								Signature
SERVICE 03	Date:																														
Engineer name:																															
Company name:																															
Telephone No:																															
Operative ID No:																															
Comments:																															
Signature																															
SERVICE 04	Date:																														
Engineer name:																															
Company name:																															
Telephone No:																															
Operative ID No:																															
Comments:																															
Signature																															
<table border="1" style="width: 100%; border-collapse: collapse;"> <tr> <td style="width: 70%;">SERVICE 05</td> <td style="width: 30%;">Date:</td> </tr> <tr><td>Engineer name:</td></tr> <tr><td>Company name:</td></tr> <tr><td>Telephone No:</td></tr> <tr><td>Operative ID No:</td></tr> <tr><td>Comments:</td></tr> <tr><td> </td></tr> <tr><td> </td></tr> <tr><td> </td></tr> <tr><td> </td></tr> <tr><td> </td></tr> <tr><td> </td></tr> <tr><td> </td></tr> <tr><td>Signature</td></tr> </table>	SERVICE 05	Date:	Engineer name:	Company name:	Telephone No:	Operative ID No:	Comments:								Signature	<table border="1" style="width: 100%; border-collapse: collapse;"> <tr> <td style="width: 70%;">SERVICE 06</td> <td style="width: 30%;">Date:</td> </tr> <tr><td>Engineer name:</td></tr> <tr><td>Company name:</td></tr> <tr><td>Telephone No:</td></tr> <tr><td>Operative ID No:</td></tr> <tr><td>Comments:</td></tr> <tr><td> </td></tr> <tr><td> </td></tr> <tr><td> </td></tr> <tr><td> </td></tr> <tr><td> </td></tr> <tr><td> </td></tr> <tr><td> </td></tr> <tr><td>Signature</td></tr> </table>	SERVICE 06	Date:	Engineer name:	Company name:	Telephone No:	Operative ID No:	Comments:								Signature
SERVICE 05	Date:																														
Engineer name:																															
Company name:																															
Telephone No:																															
Operative ID No:																															
Comments:																															
Signature																															
SERVICE 06	Date:																														
Engineer name:																															
Company name:																															
Telephone No:																															
Operative ID No:																															
Comments:																															
Signature																															
<table border="1" style="width: 100%; border-collapse: collapse;"> <tr> <td style="width: 70%;">SERVICE 07</td> <td style="width: 30%;">Date:</td> </tr> <tr><td>Engineer name:</td></tr> <tr><td>Company name:</td></tr> <tr><td>Telephone No:</td></tr> <tr><td>Operative ID No:</td></tr> <tr><td>Comments:</td></tr> <tr><td> </td></tr> <tr><td> </td></tr> <tr><td> </td></tr> <tr><td> </td></tr> <tr><td> </td></tr> <tr><td> </td></tr> <tr><td> </td></tr> <tr><td>Signature</td></tr> </table>	SERVICE 07	Date:	Engineer name:	Company name:	Telephone No:	Operative ID No:	Comments:								Signature	<table border="1" style="width: 100%; border-collapse: collapse;"> <tr> <td style="width: 70%;">SERVICE 08</td> <td style="width: 30%;">Date:</td> </tr> <tr><td>Engineer name:</td></tr> <tr><td>Company name:</td></tr> <tr><td>Telephone No:</td></tr> <tr><td>Operative ID No:</td></tr> <tr><td>Comments:</td></tr> <tr><td> </td></tr> <tr><td> </td></tr> <tr><td> </td></tr> <tr><td> </td></tr> <tr><td> </td></tr> <tr><td> </td></tr> <tr><td> </td></tr> <tr><td>Signature</td></tr> </table>	SERVICE 08	Date:	Engineer name:	Company name:	Telephone No:	Operative ID No:	Comments:								Signature
SERVICE 07	Date:																														
Engineer name:																															
Company name:																															
Telephone No:																															
Operative ID No:																															
Comments:																															
Signature																															
SERVICE 08	Date:																														
Engineer name:																															
Company name:																															
Telephone No:																															
Operative ID No:																															
Comments:																															
Signature																															
<table border="1" style="width: 100%; border-collapse: collapse;"> <tr> <td style="width: 70%;">SERVICE 09</td> <td style="width: 30%;">Date:</td> </tr> <tr><td>Engineer name:</td></tr> <tr><td>Company name:</td></tr> <tr><td>Telephone No:</td></tr> <tr><td>Operative ID No:</td></tr> <tr><td>Comments:</td></tr> <tr><td> </td></tr> <tr><td> </td></tr> <tr><td> </td></tr> <tr><td> </td></tr> <tr><td> </td></tr> <tr><td> </td></tr> <tr><td> </td></tr> <tr><td>Signature</td></tr> </table>	SERVICE 09	Date:	Engineer name:	Company name:	Telephone No:	Operative ID No:	Comments:								Signature	<table border="1" style="width: 100%; border-collapse: collapse;"> <tr> <td style="width: 70%;">SERVICE 10</td> <td style="width: 30%;">Date:</td> </tr> <tr><td>Engineer name:</td></tr> <tr><td>Company name:</td></tr> <tr><td>Telephone No:</td></tr> <tr><td>Operative ID No:</td></tr> <tr><td>Comments:</td></tr> <tr><td> </td></tr> <tr><td> </td></tr> <tr><td> </td></tr> <tr><td> </td></tr> <tr><td> </td></tr> <tr><td> </td></tr> <tr><td> </td></tr> <tr><td>Signature</td></tr> </table>	SERVICE 10	Date:	Engineer name:	Company name:	Telephone No:	Operative ID No:	Comments:								Signature
SERVICE 09	Date:																														
Engineer name:																															
Company name:																															
Telephone No:																															
Operative ID No:																															
Comments:																															
Signature																															
SERVICE 10	Date:																														
Engineer name:																															
Company name:																															
Telephone No:																															
Operative ID No:																															
Comments:																															
Signature																															

UK WARRANTY

As the purchaser of this high quality Rinnai Water Heater you are provided with the following conditional warranty.

	Heat Exchanger		All Other Parts	
	Parts	Labour	Parts	Labour
Standard Use	3 Years	1 Year	3 Years	1 Year
Rinnai 26i				
Commercial Use	5 Years	1 Year	5 Years	1 Year
HD50e / HD70e				
HD50i / HD70i				

Definition of Standard Use.

The warranty period allocated under Standard Use is based on Domestic and Light Commercial hot water usage. Rinnai Standard Use warranty periods apply only where Rinnai water heaters are installed in domestic and light commercial situations at operating temperatures below 65°C and do not include installations incorporating storage cylinders or building flow and return systems.

The warranty shall apply to any Rinnai water heater.

Definition of Commercial Use.

The warranty period allocated under Commercial Use are for Rinnai water heaters installed at premises such as commercial and industrial buildings, cafes, caravan parks, and sporting complexes. Commercial Use warranty applies to:

- Water heaters supplying a central shower block.
- Water heaters supplying kitchens used for the bulk preparation of food.
- Water heaters set to 65°C or higher.
- Water heaters used in commercial or industrial processes.
- Any application that uses Rinnai water heaters in conjunction with storage tanks.
- Any application that uses Rinnai water heaters in conjunction with a flow / return system.
- Water heaters installed as components of centralised bulk hot water systems.

Rinnai units used in Commercial Situations are only subject to a 1 year warranty across the board.

No Rinnai warranty will cover damage/ faults arising from moving or storing the unit; improper installation or gas supply; water contaminants beyond defined limits; environmental factors; plumbing fittings, or other outside influences of which Rinnai is not responsible. Service calls for these issues will be chargeable.

The unit must be serviced annually to validate the warranty.

The warranty period begins on customer's date of purchase.

Description	pH	Total Dissolved Solids (TDS)	Total Hardness	Chlorides	Magnesium	Calcium	Sodium	Iron
Maximum Recommended Levels	6.5 - 9.0	600 mg/litre	150 mg/litre	300 mg/litre	10 mg/litre	20 mg/litre	150 mg/litre	1 mg/litre

UK WARRANTY

WHAT IS COVERED?

This Warranty covers any defects in materials or workmanship when the product is installed and operated according to Rinnai installation instructions, subject to the terms within this limited warranty document. This Warranty applies only to products that are installed by a registered gas engineer. Improper installation may void this Warranty. This Warranty extends to the original purchaser and subsequent owners, but only while the product remains at the site of the original installation. This Warranty only extends through the first installation of the product and terminates if the product is moved or reinstalled at a new location.

WHAT WILL RINNAI DO?

Rinnai will repair or replace the product or any part or component that is defective in materials or workmanship, except as set forth below: All repairs must be performed using genuine Rinnai parts. All repairs or replacements must be performed by a registered gas engineer. Replacement of the product or replacement of the heat exchanger may only be authorised by Rinnai. Rinnai does not authorise any person or company to assume for it any obligation or liability in connection with the replacement of a product or heat exchanger. If Rinnai determines that repair of a product is not possible, Rinnai will replace the product with a comparable product, at Rinnai's discretion. If a component or product returned to Rinnai is found to be free of defects in material or workmanship, or damaged by improper installation the warranty claim may be denied.

HOW DO I GET SERVICE?

Contact your supplier or Rinnai UK.

Proof of date of purchase is required to obtain warranty service. You can show proof of purchase with a dated invoice or by completing and returning the enclosed Warranty registration card.

Receipt of warranty registration by Rinnai will constitute proof-of-purchase for this product. However, Warranty registration is not necessary in order to validate this Warranty.

WHAT IS NOT COVERED?

This Warranty does not cover any failures or operating difficulties due to accident, abuse, misuse, alteration, misapplication, acts of God, improper installation, improper maintenance or service, inadequate water quality, scale buildup, freeze damage or for any other causes other than defects in materials or workmanship. This warranty does not apply to any product whose serial number or manufacture date has been defaced.

This Warranty does not cover any product when used as a pool or spa heater.

Rinnai is not liable for any special, incidental, indirect or consequential damages that may arise, including damage to person or property, loss of use, failure to install drain pan under unit, or inconvenience.

This warranty does not effect your statutory rights as defined in the UK.

PRODUCT FICHE

Supplier's Name	Rinnai UK Ltd
Model Name	REU-VR2632FFUD-E REU-VR2632FFUDHD-E
<u>Declared Load Profile on Energy Label</u>	XL
Energy Efficiency Class	A
Water Heating Efficiency η_{wh} (%)	82.3
Annual Electricity Consumption AEC (kWh/annum)	14
Annual Fuel Consumption AFC (GJ/annum)	18
<u>Second Load Profile</u>	XXL
Energy Efficiency Class	B
Water Heating Efficiency η_{wh} (%)	78.9
Annual Electricity Consumption AEC (kWh/annum)	15
Annual Fuel Consumption AFC (GJ/annum)	24
Default Thermostat Setting (°C)	55/HD Range 65
Sound Power Level L_{WA} (dB)	64

*Values are tested with Natural Gas, G20, and temperature setting at 60°C under the reg. 812/2013 and calculated based on the gross calorific value (Hs).

PRODUCT FICHE

Supplier's Name	Rinnai UK Ltd
Model Name	REU-VRM3237W-E REU-VRM3237WHD-E
<u>Declared Load Profile on Energy Label</u>	XL
Energy Efficiency Class	A
Water Heating Efficiency η_{wh} (%)	83.2
Annual Electricity Consumption AEC (kWh/annum)	10
Annual Fuel Consumption AFC (GJ/annum)	18
<u>Second Load Profile</u>	XXL
Energy Efficiency Class	B
Water Heating Efficiency η_{wh} (%)	79.6
Annual Electricity Consumption AEC (kWh/annum)	9
Annual Fuel Consumption AFC (GJ/annum)	24
Default Thermostat Setting (°C)	55/HD Range 65
Sound Power Level L_{WA} (dB)	-

*Values are tested with Natural Gas, G20, and temperature setting at 60°C under the reg. 812/2013 and calculated based on the gross calorific value (Hs).

CONTACT

Rinnai UK LTD.

9 Christleton Court

Manor Park

Runcorn

Cheshire

WA7 1ST

Tel. 01928 531870

Fax. 01928 531880

E-mail. info@rinnaiuk.com

Web. www.rinnaiuk.com

HEATER DETAILS

Model Number _____

Serial Number _____

Date of Purchase _____

15/10/05(RJ)



060 00012 31437 3

(VR2632, VRM3237, UK)
U287-3089X02(00)