

# Rinnai

## Installation and User Manual

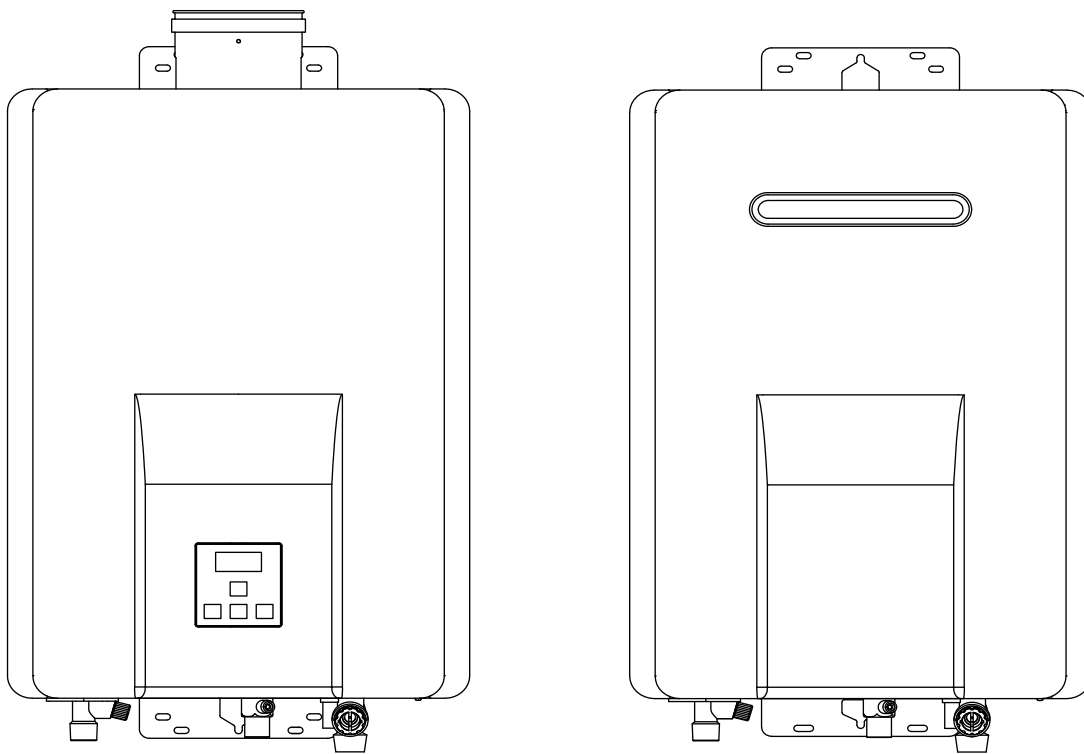

## Continuous Flow Water Heater

REU-A1111FFU-E(UK)  
REU-A1720FFU-E(UK)  
REU-A1720W-E(UK)

This appliance must be installed in accordance with:

- Manufacturer's installation instructions;
- National laws, local regulations and municipal building codes.

This appliance must be installed and maintained by competent person.

Read the instructions before attempting installation or use of this appliance.





The Rinnai *Infinity* water heater is CE Marked as allowed by *Technigas*.

***REU-A1110FFU-E(UK)***  
***REU-A1720FFU-E(UK)***

***REU-A1720W-E(UK)***

Certificate number:  
ID number:  
Date of Issue:  
Last revision:



### **Quality system standard**

ISO 9001

The design, development and manufacture of gas water heating appliances done under Rinnai's quality management system is certified under the quality management system Standard ISO 9001.

Certified by: *Japan Gas Appliances Inspection Association - JIA-QA Center*

Rinnai, constantly striving to improve the products, reserves the right to modify the details given in this documentation at any time and without notice.

From the time this manual is printed and attached to the product, to the time the product is purchased and installed, the instructions and warnings may have changed: for Your interest and Your protection we recommend that You follow the instructions and warnings reported on the most recent version of the manual which is always available on the Rinnai UK web site ([www.rinnaiuk.com](http://www.rinnaiuk.com)).

Rinnai disclaims any liability due to printing or transcription errors and reserves the right to update and change any technical and commercial lists without prior notice.

Dear Customer, our compliments for having chosen a Rinnai top quality product, able to assure wellbeing and safety for a long period of time. As a Rinnai Customer you can also count on a qualified aftersales service to guarantee a constant efficiency of Your appliance.

The following pages are very important and contain useful instructions and suggestions on the correct use of Your appliance.

## GENERAL ADVISE

Rinnai products are provided with a packaging suitable for transport. The product must be stored in dry environments and protected from bad weather.

This manual is part of the product and must be left to the new user in the case of property change of the appliance. The manual must be kept in a safe place and carefully consulted as all warnings provide important safety instruction for the installation, the use and the maintenance.

This manual contains technical information on how to install the product: for any issue related to the installation, comply with the national and local laws in force and technical standards. According to legislation in force, the systems must be designed by qualified technicians. Installation and maintenance must be performed in compliance with the regulation in force, according to the manufacturer's instructions and by qualified personnel.

An improper installation or assembly of the appliance (components, accessories, kits, etc.) can cause unexpected problems to people, animals and property.

The product must be destined to the use for which it is designed for. Any other use will be considered as improper and therefore potentially dangerous.

In case of any errors in the installation, the use or the maintenance due to non compliance of the laws in force, Standards or manufacturer's instructions, the manufacturer is excluded from any contractual and extra contractual liability for any damages and the appliance warranty is invalidated.

The user may not install or adjust the appliance in any way that requires the removal of the front cover of the unit: to remove the front cover of the unit you must be certified competent to do so.

## IMPORTANT

According to local laws in force, heating and hot water systems are subject to regular maintenance and regular checking of the heating performance. To comply with these obligations we invite You to contact the Rinnai local service.

**Information on disposal of the product:** the symbol shown here indicates that, according to the laws and local regulations, the product must be disposed of with household waste. At the end of its life, the appliance must be delivered to a collection point identified by local authorities. The separate collection and recycling of the product at the time of disposal will help conserve natural resources and ensure that it is recycled in order to protect health and the environment.



For further information on regulations related to the installation of the water heater or to find out your closest authorized Rinnai service company You can contact:

---

## RinnaiUK LTD

9 CHRISTLETON COURT, MANOR PARK,  
RUNCORN, WA7 1ST  
01928 531870  
[WWW.RINNAIUK.COM](http://WWW.RINNAIUK.COM)

# CONTENTS

<b>WARRANTY</b> .....	<b>5</b>
<b>USER'S INSTRUCTIONS</b> .....	<b>6</b>
FEATURES AND BENEFITS.....	7
IMPORTANT SAFETY INFORMATION.....	8
OPERATION.....	10
SELECTABLE TEMPERATURES.....	11
OPERATION WITH THE STANDARD CONTROL PANEL.....	11
OPERATION WITH MULTIPLE CONTROL PANELS.....	12
OPERATIONAL SAFETY INFORMATION.....	13
TROUBLE SHOOTING.....	14
ERROR CODES.....	14
TROUBLE SHOOTING WITHOUT CONTROLLERS (OUTDOOR MODELS).....	15
MAINTENANCE.....	16
<b>INSTALLER'S INSTRUCTIONS</b> .....	<b>16</b>
IMPORTANT INFORMATION.....	17
INSTALLATION WARNINGS.....	18
APPLIANCE LOCATION.....	18
UNPACKING THE WATER HEATER.....	19
MAIN COMPONENTS - OUTDOOR MODELS.....	19
MAIN COMPONENTS - INDOOR MODELS.....	20
DIMENSIONS.....	21
GENERAL SCHEME AND OPERATION PRINCIPLES.....	22
INSTALLATION.....	23
CLEARANCE.....	23
WATER CONNECTION.....	23
GAS CONNECTION.....	23
ELECTRICAL CONNECTION.....	24
CONTROL BOARD DIP-SWITCH SETTING.....	24
FLUEING.....	25
REMOTE CONTROLLER.....	27
CONTROL PANEL PROGRAMMING.....	29
COMMISSIONING.....	30
BENCHMARK.....	31
<b>MAINTENANCE INSTRUCTIONS</b> .....	<b>32</b>
PCB INTERFACE LAYOUT AND FUNCTIONS.....	32
DATA TRANSFER BETWEEN PCB'S.....	33
GAS CONVERSION AND PRESSURE ADJUSTMENT.....	34
WATER FLOW CHART.....	35
FLOW CHART.....	36
WIRING DIAGRAM AND DIAGNOSTIC POINTS.....	37
MAINTENANCE.....	38
SERVICE RECORD.....	39
FLUSHING THE HEAT EXCHANGER.....	40
MANUAL DRAINING OF THE WATER HEATER.....	41
TECHNICAL DATA.....	42
PRODUCT FICHE.....	45
CE Certificate.....	46



# WARRANTY

Dear Customer,

Our compliments for having chosen a Rinnai product.

The standard Rinnai warranty does not affect the terms of the legal warranty on customer's good and relates to Rinnai products purchased.

## WARRANTY PERIOD

This appliance will come with a 4 Year parts warranty, 1 Year Labour warranty.

## WHAT IS COVERED?

The warranty covers any defects in materials or workmanship when the product is installed and operated according to Rinnai installation instructions, subject to the terms within this limited warranty document. This warranty applies only to products that are installed by a registered gas engineer. Improper installation may void the warranty. This warranty extends to the original purchaser and subsequent owners, but only while the product remains at the site of the original installation. The warranty only extends through the first installation of the product and terminates if the product is moved or reinstalled at a new location.

## WHAT WILL RINNAI DO?

Rinnai will repair or replace the product or any part or component that is defective in materials or workmanship, except as set forth below:

- all repairs must be performed using genuine Rinnai parts.
- all repairs or replacements must be performed by a registered gas engineer.

Replacement of the entire product or replacement of any parts may only be authorised by Rinnai.

Rinnai does not authorise any person or company to assume for it any obligation or liability in connection with the replacement of a product or heat exchanger. If Rinnai determines that repair of a product is not possible, Rinnai will replace the product with a comparable product, at Rinnai's discretion. If a component or product returned to Rinnai is found to be free of defects in material or workmanship, or damaged by improper installation the warranty claim may be denied.

## HOW DO I GET SERVICE?

Contact your supplier or Rinnai.

Proof of date of purchase is required to obtain warranty service. You can show proof of purchase with a dated invoice or by completing and returning the enclosed warranty registration card.

Receipt of warranty registration by Rinnai will constitute proof-of-purchase for this product. However, warranty registration is not necessary in order to validate this warranty.

The Benchmark sheet located in this manual must be fully completed upon installation and kept with the appliance. If a warranty is requested the Benchmark sheet may be requested, failure to provide this may result in the refusal of any labour costs Rinnai may otherwise incur.

## WHAT IS NOT COVERED?

This warranty does not cover any failures or operating difficulties due to accident, abuse, misuse, alteration, misapplication, extreme weather conditions, improper installation, improper maintenance or service, inadequate water quality, scale build-up, freeze damage or for any other causes other than defects in materials or workmanship. This warranty does not apply to any product whose serial number or manufacture date has been defaced.

Rinnai is not liable for any special, incidental, indirect or consequential damages that may arise, including damage to person or property, loss of use, failure to install drain pan under unit, or inconvenience. This warranty does not effect your statutory rights as defined by European laws.

This appliance must be serviced at least once a year. Failure to do so will invalidate the warranty. All service records must be kept as Proof of Service. Failure to provide these for any warranty claim may result in the claim being denied.

# USER INSTRUCTIONS

The following instructions are designed for the user of the water heater. The user may not install or adjust the appliance in any way that requires the removal of the front cover of the unit. To remove the front cover of the unit you must be certified competent to do so.

Information for the Installer is given on page 19.

All work done on this appliance must be done by a qualified gas engineer. A qualified gas engineer must carry an up to date GAS SAFE Registered Gas Installer photo identification card while working on gas appliances. If you are unsure do not be afraid to ask the engineer to show you the card. If you are still not satisfied call GAS SAFE on 0800 408 5500 and verify the engineer's name with their database. This is for your own safety.

## Responsibilities of the USER

The user must abide by all warnings given in this book. The user must only reference the user section of the book, and may not carry out any procedure listed in the installer section. This installation manual should be kept with the appliance for maintenance and user information.

The user must have the unit checked and maintained annually by a gas engineer.

The user must periodically check the water filter on the inlet to the appliance.

The user must not use the appliance in any way that it was not meant to be used. The user may only use the heater as detailed in the User portion of this manual.

Interference with a sealed component is not permitted. In case of defect parts only use genuine Rinnai components for replacement.

Conversion to other gas types should only be carried out by a qualified installer or a gas distributor according to the practice in the country where the unit is installed.

The user must not store or use any flammable vapors or liquids in the vicinity of this or any other appliance.

The user should familiarise themselves with the water heaters gas service valve and the main gas valve to the premises.

**ATTENTION:** air surrounding the water heater, venting and vent termination(s) is used for combustion and must be free of any compounds that cause corrosion of internal components. These include corrosive compounds that are found in aerosol sprays, detergents, bleaches, cleaning solvents, oil based paints/ varnishes, and refrigerants. Therefore Rinnai recommends outdoor models be used for these locations where possible.

The water heater, venting and vent termination(s) should not be installed in any areas where the air may contain these corrosive compounds. If it is necessary for a water heater to be located in areas which may contain corrosive compounds, Rinnai strongly recommends the following:

Indoor/Internal Water Heaters:

- \* DO NOT install in areas where contaminated air is present
- \* Consider before installation where air has the ability to travel within the building
- \* Where possible, install the water heater in a sealed closet so that it is free of contaminated indoor air
- \* Chemicals that are corrosive in nature should not be stored or used near the water heater

Outdoor/External Water Heaters and Vent Terminations of Indoor/Internal Water Heaters:

- \* Install as far away as possible from exhaust vent hoods
- \* Install as far away as possible from air inlet vents. Corrosive fumes may be released through these vents when air is not being brought in through them.
- \* Chemicals that are corrosive in nature should not be stored or used near the water heater or vent termination.

Damage and repair due to corrosive compounds in the air is not covered by warranty.

The exhaust outlet may change colour over time due to the condensate in the exhaust gases. This discoloration does not damage the part or its form, fit or function.



Benchmark places responsibilities on both manufacturers and installers. The purpose is to ensure that customers are provided with the correct equipment for their needs, that it is installed, commissioned and serviced in accordance with the manufacturer's instructions by a competent person(s) and that it meets the requirements of the appropriate Building Regulations. The Benchmark Checklist can be used to demonstrate compliance with Building Regulations and should be provided to the customer for future reference.

Installers are required to carry out installation, commissioning and servicing work in accordance with the Benchmark Code of Practice which is available from the Heating and Hot water Industry Council who manage and promote the Scheme. Visit [www.centralheating.co.uk](http://www.centralheating.co.uk) for more information.

## IF YOU SMELL GAS

**Isolate the gas supply and get out of the building. Do not try to light any appliance. Do not turn any light or other electrical switch on or off. Do not use any telephone in the building. Call your gas engineer from a safe location and follow their instructions. If you cannot reach your gas engineer ring the following:  
National Grid 0800 111 999**

## Features and Benefits

Congratulations on purchasing the latest technology temperature controlled Rinnai continuous flow water heating system.

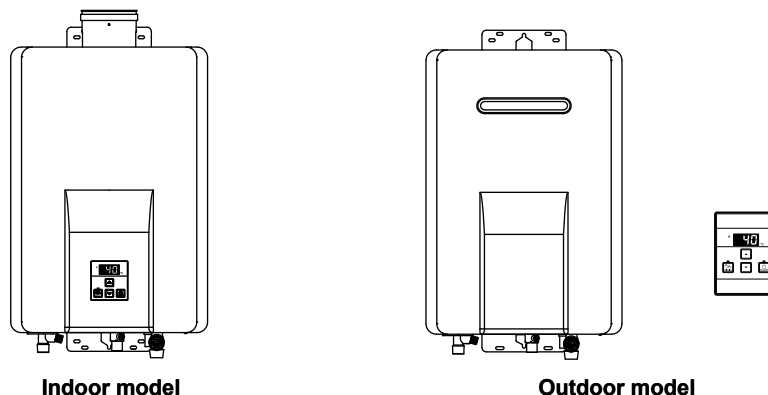

The Rinnai continuous flow water heater products **NEVER RUN OUT** of hot water. Whilst electricity, water and gas supplies are connected, hot water is available whenever hot water taps are open.

Built into the main micro-processor is the facility to **LIMIT THE MAXIMUM TEMPERATURE** of the hot water supplied. The water temperature may be limited to various values. This is particularly useful when the hot water unit is installed where young children or the infirm may be using the hot water.

The Rinnai continuous flow water heater products are fan-assisted (power flued) appliances. This makes them **COMPACT**, saving both floor and wall space.

The temperature of hot water is **CONSTANTLY MONITORED** by a **BUILT-IN SENSOR**. If the temperature of the hot water rises to more than 3°C above the selected temperature the burner is turned OFF and only turned ON again when the temperature falls below the selected temperature.

The burner lights automatically when the hot water tap is opened, and goes out when the tap is closed. **IGNITION IS ELECTRONIC**, so there is no pilot light. When the hot water tap is off, no gas is used.

'Deluxe' or 'Universal' Water Controllers are available as an optional extra. Depending on the models chosen, these offer the following features:

- Bath fill function (Deluxe Bathroom Control Only).
- Voice Prompting (Deluxe Control Only).
- Clock (Deluxe Control Only).
- Up to four water controllers can be fitted.

For further information regarding Deluxe water controllers please contact Rinnai or visit [www.rinnaiuk.com](http://www.rinnaiuk.com)









Operating **NOISE LEVEL IS VERY LOW**.

**ERROR MESSAGE ARE DISPLAYED** on the Water Controllers, assisting with service.

An **ANTIFROST PROTECTION SYSTEM** is provided on each unit (indoor models included): heating ceramic resistances are electrically powered to protect the appliance up to temperatures of **-20°C** for outdoor units, and up to **-15°C** for indoor models.

# IMPORTANT SAFETY INFORMATION

Meaning of the symbols used in the manual for important safety information:

	Indicates a situation of potential serious danger, to respect and follow carefully.
	Indicates a potentially hazardous situation which, if not avoided, may lead to injury or property damage.
	Indicates an important information.
	Information on the correct use, installation and operation of the product.
	Indicates a potential condition of serious danger which must be complied.
	Indicates a condition which should be avoided.
	Indicates a ground connection for the prevention of an electric shock.
	Warns of a risk of fire. Keep the area clean and free from flammable materials.
	Warns of a risk of injury or property damage when contacting.

 **The appliance should be installed by qualified personnel only.**  
**OUTDOOR models must be installed outdoors, always open air and well aerated areas.**  
**INDOOR models can be installed outdoor, in partially protected areas: not directly exposed to weather conditions.**  
**Use the appliance only for water heating.**

Use the appliance to heat sanitary hot water: for any different use, please contact Rinnai.

Do not modify this appliance: do not attempt to repair, replace or open sealed parts or disassemble the appliance.

Improper adjustment, alteration, service or maintenance could significantly affect the safety of the product: for any kind of repair, modification of the settings or maintenance of the product and its accessories, it is recommended to contact the Rinnai Technical Department.

Use original Rinnai parts to repair the appliance.

In case of unusual noise, vibration or smell, stop the appliance and contact Rinnai for further information

If you smell gas:

- isolate the main gas supply;
- open doors and windows;
- call your gas engineer;

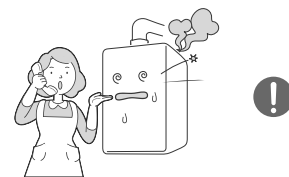

Use a telephone outside the building.

In fire, gas leak, unusual noise or smell, isolate the gas and power supply and open doors and windows.

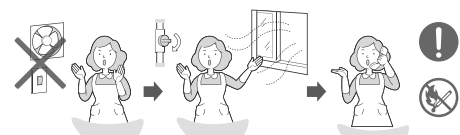

Water temperature over 50°C can cause severe burns instantly or even death from scalding. Hot water at 60°C can severely burn a child in less than a second. At 50°C it takes five minutes. Always test the temperature of the water before any use. To prevent these risks, Rinnai recommends to consider setting your hot water production at a maximum temperature of 50°C.

Do not store flammable objects near the appliance: it could cause a product failure or fire. Do not spray aerosols in the vicinity of this appliance while it is in operation.

Check that the appliance is supplied with the correct gas type and pressure according to the data plate: ensure that the gas in use matches with the gas indicated on the data plate. If not, there could be incomplete burning of the gas, resulting in toxic emissions and/or product failure.

Do not insert objects into the flue outlet. Do not spray water directly into the flue outlet. Keep, trees, shrubs, etc. well clear of the flue outlet. On colder days steam may discharged from the flue outlet. This condition is normal for high efficiency appliances and does not indicate a fault.

Do not touch the unit cover or the flue outlet.

Check the main gas valve to make sure it is opened before using the appliance and check the gas pressure is correct.

Copper or Stainless Steel pipes are recommended for gas and water supply; rubber hose might get damaged.

It is recommended to install valves on the gas and water pipes to allow an easier maintenance and to increase safety in case of emergency.

Check the voltage at the power outlet to make sure it is within the appropriate range before use. Ensure the electrical system is provided with an appropriate grounding, otherwise the appliance could be severely damaged or operate improperly.

The extension of the power cord should be avoided (e.g. using an extension cord or a multiple socket). If the supply cord is damaged, it must be replaced by the manufacturer, its service agent or similarly qualified persons in order to avoid a hazard.

Prior to use after installation or if the appliance has not been used for a long time let the hot water flow for a while before using.

It is recommended to install a system to collect and drain water under the appliance in the case of water leakage to prevent material and property damages.

**Frost protection:** Make sure that the power cord of the appliance is plugged-in and the electrical power is always available.

The frost protection system activates only when the appliance is electrically powered and switched ON.

All pipes must be wrapped with insulating materials to prevent heat loss. The thickness of insulation should be between 25mm and 50mm according to outdoor temperatures. Trace Heating could be installed to protect pipework subjected to extreme cold or wind chill conditions. Trace Heating is recommended if the case of temperature drops below -15°C/-20°C.

If extremely freezing conditions are expected, turn off water and gas, and drain all water from the appliance. If power and the automatic frost protection are connected, freezing will be prevented. (Anti-frost protection is fitted as standard equipment on all hot water units)

If water pipes are frozen, there would not be water flow in the system. Use a heat source (e.g. hair dryer) to unfreeze the frozen components and pipes. Before using the appliance after defrosting contact the Rinnai service to verify possible damages.

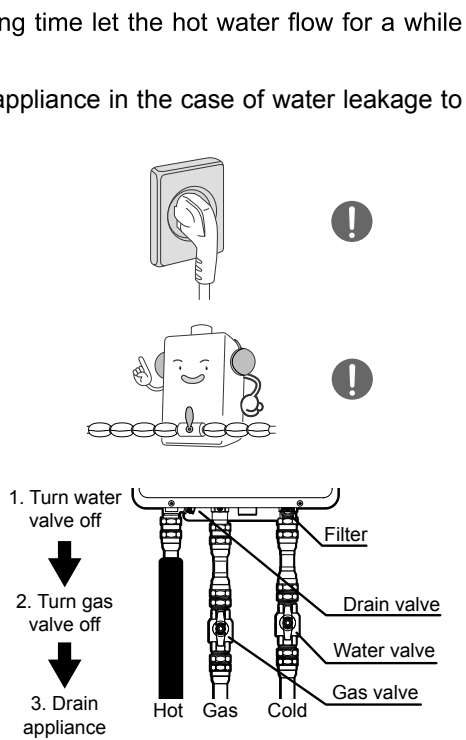
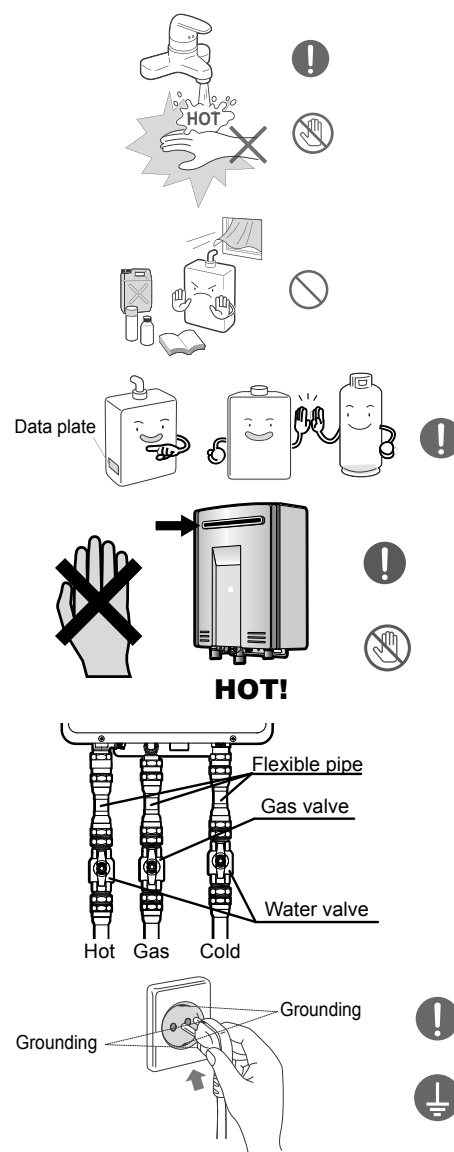

# OPERATION

The Rinnai water heater is able to supply hot water at a constant set temperature. Sudden changes that result from the simultaneous use of several outlets or from variations in the temperature of the cold water used to feed the appliance (pre-heated water from solar panels, etc.) will not affect the temperature from the appliance.

To maximize these benefits, increasing comfort and reducing consumption, Rinnai recommends setting the appliance to the minimum temperature most suitable for the intended use and using hot water without mixing with cold.

The Rinnai instantaneous water heaters do not have a 'pilot flame'. The opening of any tap will immediately activate the electronic ignition: as soon as the water flows through the appliance, the burner is turned on by an electronic system; when the tap is closed and the water flow stops, the appliance completely switches off the burner flame.

Inside the appliance, the water temperature is monitored by several integrated sensors: when the hot water temperature exceeds 3°C the set value, the 'In Use' indicator  on the control switches off. This means that the appliance burner is switched off and that the water is no longer heated until the temperature has dropped below this value.

All Rinnai water heaters are equipped with a control panel for general appliance control, hot water temperature selection and diagnostic functions. The control panel allows you to have full control over the appliance and to adapt it in a simple and immediate way to the use of hot water according to your needs.

In the indoor models, the control panel is integrated on the front panel of the appliance and cannot be removed; in the outdoor models, the control panel is available as a remote control to be connected to the appliance by means of a cable that can be remotely installed in a domestic environment.

The outdoor models can operate without connecting the remote control: the operation of the appliance remains the same as described previously, but the water heater works at a fixed temperature and it is not possible to change the value to adapt it to different needs.

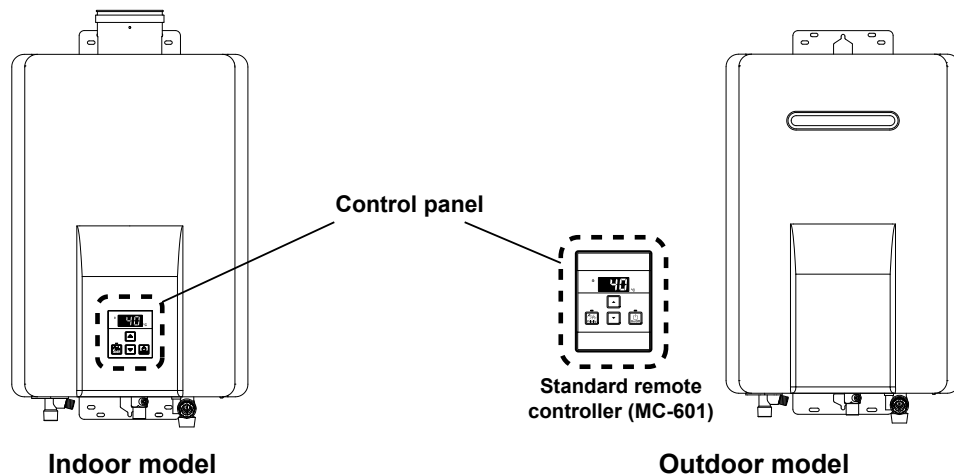

To be able to control the device from different environments, more conveniently, you can add three additional remote commands to the initial configuration, for a maximum of four control panels. Additional remote controls are optional accessories. However, only one control panel can be set as 'Master' (or main): normally this is the one placed in the kitchen is selected. The additional control panels are automatically designated as 'Sub' (or secondary) commands and are usually installed in environments such as the bathroom, the laundry, etc.

The maximum temperature available for secondary controls is always limited to 50°C from the system: this is to ensure maximum comfort of use and above all to prevent the risk of burns during use in the environments in which they are installed.

All control panels are individually programmable, although the appliance only heats the water at one temperature at a time.

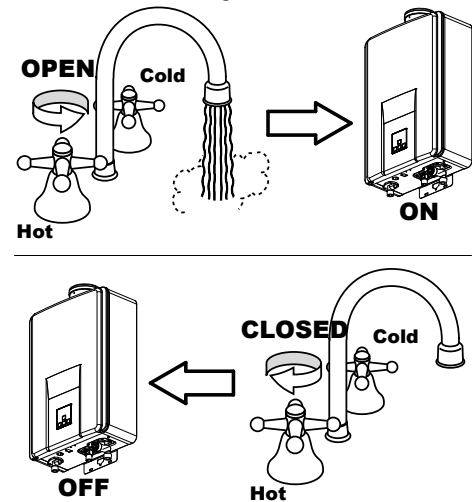

## Selectable Temperatures

The appliance is set at the factory to allow the selection of a maximum temperature of 55°C. This limit is generally more than adequate for most domestic uses, but it is possible to modify it according to your needs. A Rinnai specialized technician can modify the device electronics by modifying the maximum allowed temperature, bringing it to a higher value or limiting it further. This change is not permitted to domestic users. Rinnai recommends setting the appliance to the minimum temperature best suited to the intended use to reduce gas consumption and to increase the life of the appliance.

The control panel supplied with the appliance is factory blocked: it is possible to increase the temperature up to a limit of 50°C. Higher temperatures can be obtained only after having unlocked the control panel: correctly performed the release procedure, it will immediately be possible to increase the delivered temperature and reach the maximum value set on the appliance. The unlocking (and locking) procedure is described in the section dedicated to installation instructions, and it is allowed to specialized personnel only.

The temperatures that can be selected using the control panels are as follows:

Selectable temperatures (°C)	Master	37, 38, 39, 40, 41, 42, 43, 44, 45, 46, 48, 50, 55, 60 <sup>1</sup> , 65 <sup>1</sup>
	Sub	37, 38, 39, 40, 41, 42, 43, 44, 45, 46, 48, 50

<sup>1</sup> selectable temperatures after changing the PCB parameters.

The temperatures below are intended as examples: you can set them according to your lifestyle. Remember that low usage temperatures help to reduce consumption.

Suggested temperatures	Kitchen	50°C ~ 55°C	Bathroom	37°C ~ 43°C
------------------------	---------	-------------	----------	-------------

Temperatures below 37°C can be obtained by mixing with cold water.

## Operation with the standard control panel

The control panel supplied with the outdoor models (Standard remote control - MC-601) and the internal models control panel (installed on the front casing) have similar appearance and functions:

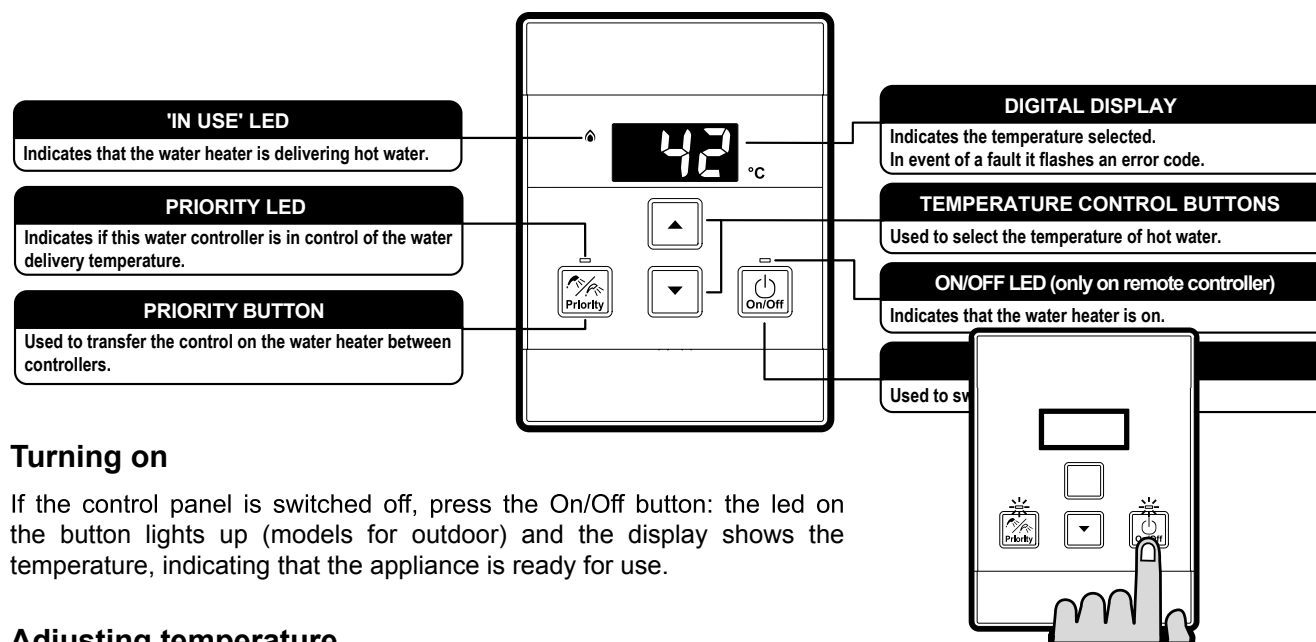

## Turning on

If the control panel is switched off, press the On/Off button: the led on the button lights up (models for outdoor) and the display shows the temperature, indicating that the appliance is ready for use.

## Adjusting temperature

Select the desired temperature using the hot water temp ▲ or ▼ buttons until the required temperature is displayed on the digital monitor.

To operate the hot water unit, open any hot water tap: the appliance will control the temperature and turn on the burner only if it is necessary to heat it. When the burner is on, the 'In Use' indicator will light up on the controls connected to the appliance.

Once the hot water is running, if the set temperature is either too hot or too cold press the hot water temp ▲ or ▼ buttons until the desired temperature is reached.

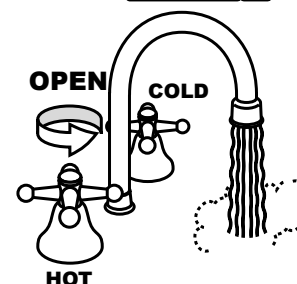



Temperatures above 50°C should not be selectable from remote controls installed in environments such as bathrooms or the like: this is to reduce the risk of burns. Contact your installer to correct the problem.

Prior to use, to avoid burns, it is recommended to always check the hot water temperature. In particular, before using hot water for children or infirm persons, an adult should always check the hot water temperature.



During hot water delivery the set temperature can always be lowered (up to a minimum of 37°C). For safety reasons, it is not possible to increase its value above 43°C: this is only possible when the withdrawal of water is stopped (all the taps are closed).

When using the appliance, if the control is switched off, it will not be possible to switch it on again until the withdrawal has been completely stopped.

To delete the 'beep' emitted by the keys on the control panel, press the ▲ and ▼ buttons at the same time for at least three seconds. Repeat the procedure to cancel the choice made.

### Transferring priority

When more than one command is installed, to change the temperature of the hot water supplied, it is necessary to transfer the 'priority' function to the desired command. The transfer of the function is not possible when the 'In Use' led is on: this means that the appliance is already heating the water and that some users are active.

The led of the 'Priority' key lights up when this function is active on the control panel. When the led is off, press the 'Priority' key once to call up the function.

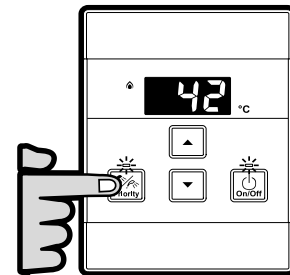

### Lock function

To prevent tampering and increase the safety level of the product, especially for children, it is possible to lock the control panel.

To lock the panel it is necessary to press, and keep pressed for about five seconds, the 'Priority' keys and the key to increase the temperature (up arrow) (Fig.1). To unlock the command it is sufficient to repeat the procedure of blocking commands.

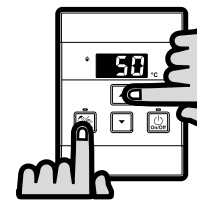

Fig. 1

When the panel is locked, the display shows 'LOC' (Fig.2) alternating with the selected temperature on the display. All connected commands will be locked and will display the same flashing text.



Fig. 2

### Operation with multiple Controllers

The installation of accessories remote commands, allows the temperature to be changed directly from different environments. The hot water will be supplied to all the users at the temperature set on the control which has the 'priority function' activated.

Standard remote controls (such as the one supplied with outdoor models: MC-601) and/or Deluxe remote controls can be connected to the device. Available Deluxe models are: the 'kitchen' model MC-100V and the 'bathroom' model BC-100V.

Standard models allow temperature selection and self-diagnosis functions.

The Deluxe remote controls, in addition to the functions of the Standard models, have an alert voice speaker, a clock function and, the Deluxe bathroom model, is equipped with an automatic bathtub filling function (contact Rinnai for further information on the commands remote Deluxe or visit the Rinnai website: [www.rinnaiuk.com](http://www.rinnaiuk.com)).

Remote controls of another brand are not compatible.

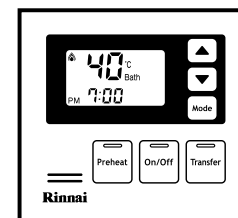

Deluxe 'kitchen' optional remote controller - MC-100V

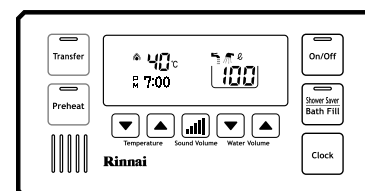

Deluxe 'bathroom' optional remote controller - BC-100V



## Operational Safety Information

The following instructions and recommendations describe some important features of the operation of the appliance.



This appliance is not intended for use by persons with reduced physical, sensory or mental abilities, or lack of experience and knowledge, unless they are supervised or instructed on the use of the appliance by a person responsible for their safety. Children should be supervised to ensure that they do not play with the appliance.

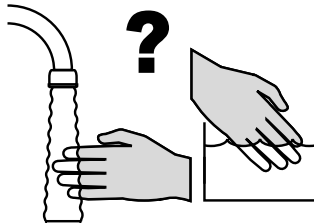

It is recommended to always test the hot water temperature before using it to avoid burns.

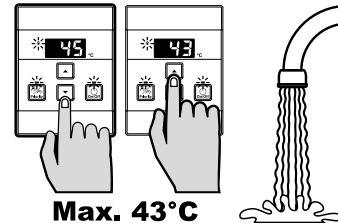

During the operation of the appliance the set temperature can be reduced; it is not possible to increase it above 43°C. Transferring the 'priority' between the commands is not permitted during operation of the device. These are security features.

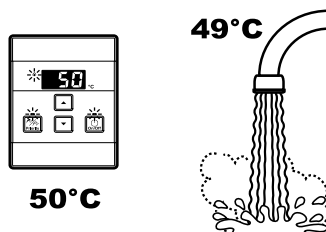

Depending on the environmental conditions, the length and the insulation of the pipes, there may be a difference between the temperature set on the control panel display and the temperature actually delivered to the tap.

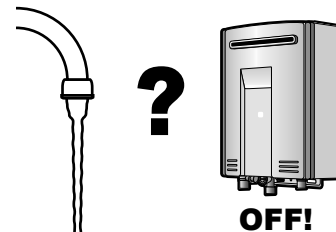

At low flow rates, the unit may switch off without warning. By opening the outlet more, the appliance will restart and restore its normal operation.

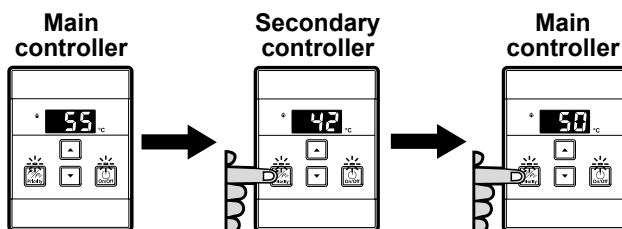

If the temperature set on the main control is >50°C and the 'priority' is transferred to a secondary command and then transferred back to the main, the temperature set on the main control is reduced to 50°C. This is a safety function.

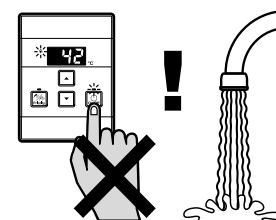

Do not press the 'ON/OFF' key on the control panel while the appliance is operating: the appliance switches off and hot water production stops.

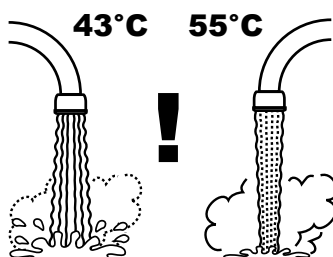

The delivered water temperature is controlled automatically and it is kept constant. The flow rate of the supplied water can instead vary depending on the selected temperature and the temperature of the water used to supply the appliance.

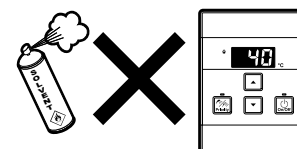

Clean the control with a soft damp cloth. Do not use aggressive detergents or solvents.

## Trouble Shooting

Rinnai products are all equipped with a self-diagnosis system: in case of failure, an error code appears on the control panel display and flashes. This function can be very useful for diagnosing the problem and tracing the causes, avoiding, where possible, the need for an external intervention by an authorized Rinnai technician. Write down the flashing error code before making the maintenance request.

To cancel the error code and to restore the normal operation of the appliance, it is necessary to stop the hot water withdrawal by closing all the taps for a few seconds. If this procedure does not solve your problem, press the 'On/Off' key to switch off the appliance, switch off the power supply for a few seconds and reset the unit. If the error code remains, it is necessary to contact an authorized Rinnai technician.

### Error codes

Code	Description	Remedy
-	Noticeable reduction in water flow.	Inlet water filter needs to be cleaned - Service call.
03	Power interruption during bath fill (water will not flow on power reinstatement)	Turn off all hot water taps. Press On/Off twice.
10	Air intake or flue blocked.	Service call.
11	No ignition / No gas supply.	Check gas is turned on at water heater and gas meter or cylinder.
12	Flame failure / Low gas flow.	Check gas is turned on at water heater and gas meter or cylinder. Check there are no obstructions to the flue outlet.
14	Remaining flame safety device.	Service call.
16	Over temperature warning.	Service call.
19	Electrical earth check fault.	Service call.
21	Incorrect dip-switch setting detected	Installer to check dip-switch settings / Service call.
32	Outgoing water temperature sensor fault.	Service call.
33	Heat exchanger outgoing water temperature sensor fault	Service call.
34	Indoor temperature sensor fault.	Service call.
41	Ambient temperature sensor fault.	Service call.
52	Gas modulating valve fault.	Service call.
61	Combustion fan fault.	Service call.
65	Water flow control fault (Does not stop flow properly).	Service call.
70	Microprocessor fault.	Service call.
71	Microprocessor fault.	Service call.
72	Flame sensing device fault.	Service call.
LC# (LC0, LC1, LC2, ...)	Scale build-up in heat exchanger (when checking maintenance code history, "00" is substituted for "LC")	<p>If remote is fitted: LC0~LC9 indicates that there is scale build up in the heat exchanger and that the heat exchanger needs to be flushed to prevent damage.</p> <p>Refer to the flushing instruction in the manual.</p> <p><b>Hard water must be treated to prevent scale build up or damage to the heat exchanger.</b></p> <p>To operate the water heater temporarily until the heat exchanger can be flushed, push the ON/OFF button on the temperature controller 5 times.</p> <p>Repeated LC codes will eventually lockout the water heater.</p> <p>Please call Rinnai technical department.</p>

## Troubleshooting Without Controllers (Outdoor Models)

If the remote control has not been installed and the following faults occur, you can follow the advice below; contact an authorized Rinnai service centre if you do not solve the problem.

Description	Remedy
The unit does not attempt to start at all.	Check the power supply. Clean the water filter. Check the water inlet on the appliance.
The unit starts then shuts down immediately.	Check the power supply. Check the gas cock. Open the hot water outlet more.
The unit starts then the water goes cold.	Check the power supply. Open the hot water outlet more.



**Faults caused by insufficient gas/water supply, insufficient quality of gas/water, installation errors, improper use of the appliance or lack of maintenance are not covered by warranty.**

## Maintenance



**Regular maintenance is recommended to keep the good condition and efficiency of the appliance unaltered and always safe to use.**

**The control panel and the appliance must only be repaired and serviced by Rinnai authorized specialist technicians: no repair or partial repair is allowed by the private user who requests the opening of the front panel of the appliance.**

**Spare parts used in maintenance must be original Rinnai parts.**

**Rinnai offers you a technical assistance network with trained and qualified personnel to provide You with the best service on Rinnai products.**

**It is recommended to write down the model and serial number of the appliance before contacting Rinnai: this information will help us to frame the problem faster and to guarantee You a better service.**

The appliance must be kept clean.

Electrically isolate the appliance and close the gas valve before proceeding with any kind of maintenance or cleaning.

Clean the outer casing and the control using soft cloths, dampened with water or non-aggressive detergents. Do not use solvents.

At the end of maintenance or cleaning, always inspect the appliance and check that no component has been inadvertently disconnected or damaged: leakages of combustion products can cause death or serious damage to the health of people and animals.

The appliance has a mesh filter on the cold water inlet. This filter requires occasional cleaning: the frequency is determined by the quality of the water used to supply the appliance. The cleaning of this filter is an operation that can be carried out by the User independently and regularly to maintain the good functioning of the product, limiting some causes of damage and damage.

To clean the filter: close the water valves; unscrew the safety valve and the filter. Remove the filter and clean it. Follow the steps in the opposite direction to reassemble.

When the filter is dirty or clogged with debris, it reduces the performance of the appliance and reduces its life.

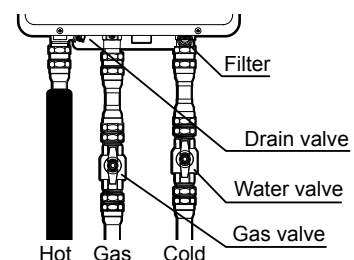

## INSTALLATION INSTRUCTIONS

# STOP

To go beyond this point in the manual you must be a registered gas engineer.

Do not attempt to install this appliance if you are not qualified. This can void the warranty.

If the information in this manual is not followed exactly a fire or explosion could result.

This manual must be read in its entirety before installing the appliance.

If you are unsure of any point contact Rinnai or your supplier.

## Important Information

This appliance may only be installed by someone certified competent to do so. At the time of printing the only people deemed competent to install this appliance are those that are **GAS SAFE** Registered for this type of appliance in this type of location who have a current ACS certificate.

1. Gas safety (Installation & Use) regulations 1998 are the 'Rules in force'. In your own interest and that of safety, it is law that all gas appliances are installed by competent persons in accordance with the above regulations. Failure to install appliances correctly could lead to prosecution. Other persons should NOT attempt to install this equipment.

2. Building Regulations G3 require installers of unvented systems to be competent to do so. Competence can be shown by holding a current certificate in Unvented Domestic Hot Water Systems. If the appliance is installed in a flow and return, or tank system, or any other closed system then the system is unvented.

3. Installation must be carried out in accordance with the current issue of the following:

Building Regulations issued by the Department of the Environment

Building Standards (Scotland) Regulations.

I.E.E. Wiring regulations for electrical installations.

Gas safety (Installation and Use) Regulations current issue.

BS 5546

BS 5440

BS 6891

BS 5482

BS 6700

BS 6644

Institute of Gas Engineers Publications

Local bylaws

Water regulations

Health and safety at work etc. Act 1974

IGE/UP/10 Part1 Edition 2.

Building Regulation J and G

Such other specifications and regulations that may supersede or complement the above documents.

It is the installer's responsibility to ensure that the unit has been installed to all current requirements.

**Please be sure that you are fully aware of your obligations and responsibilities under these regulations.**

**In case of defective parts only use genuine Rinnai components for replacement failure to do so will invalidate any warranty.**

### Disposal Information:

Under the laws and local regulations, this product must be disposed separately from household waste. When this product reaches the end of useful life, it should be taken to a collection point identified by the local authorities. The recycling of the product at the time of disposal will help conserve natural resources and ensure that it is recycled in a manner that protects human health and environment.

# Installation Warnings



*The following section contains technical information regarding the installation of the product. For what concerns issues related to the installation (safety, environmental protection, accident prevention, etc.) it is necessary to respect the dictates of the current legislation and the principles of good technique. Under the current law, the systems must be held by qualified professionals.*

## APPLIANCE LOCATION

The outdoor models are designed for outdoor installation only: they must be installed in a raised position in the open air with natural ventilation, without standing areas; where the losses of gas and combustion products are rapidly dispersed by wind or by natural convection.

**The OUTDOOR models can be installed outdoors without protection from rain, snow, etc. The minimum ambient temperature allowed for normal operation is -20°C.**

**The INDOOR models can be installed in outdoor environments, partially protected: not exposed to direct action of atmospheric precipitation. The minimum environmental temperature allowed for normal operation is -15°C.**

**All pipes must be insulated with appropriate insulating materials to prevent freezing.**

The appliance must be fixed to a flat vertical support wall, with the gas and water connections facing downwards. The positioning of the flue gas exhaust terminal must comply with the regulations in force and respect the minimum distances from the architectural elements.

The water heater must be positioned minimizing the distance of the utilities that use it most frequently to reduce the wait for hot water from the appliance to the points of use.

It is necessary to provide an electrical plug with AC230V/50Hz and grounding power supply near the appliance, sufficiently far from the gas, the water connections of the appliance and from the flue exhaust. For outdoor installations it is necessary to provide a protected and waterproof outlet. The electrical cable of the appliance is 1.5m long.

The appliances must be positioned ensuring access without risk or excessive difficulty for inspection, repairs and emergency interventions. Sufficient space for component removal and product maintenance must be guaranteed.

This product can not be used for direct heating of swimming pool water.

Both brackets (upper and lower) must be fixed to the wall using metal anchors.





Provide an adequate system for collecting and disposing of liquids in the lower part of the appliance to prevent damage to property in the event of accidental breakage of pipes.

The air around the appliance, the exhaust and ventilation apparatus, is used for flame combustion: it must be free of any element that may cause corrosion of the components (this includes corrosive substances, for example, in aerosols, sprays, detergents, chemical solvents, oil-based paints, refrigerants, etc.). The appliance and its exhaust and ventilation apparatus must not be installed in environments where corrosive, combustible or chemical substances are present. Damage and repairs due to corrosive compounds in the air are not covered by warranty.

Installations in coastal areas may require more frequent maintenance due to corrosive phenomena of the sea air.

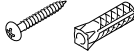
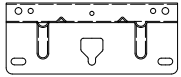
# Unpacking the Water Heater

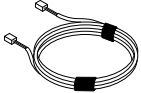
Before installation, check that the product is prepared for the type of gas used and that it is free of damage. If you find any damage to the appliance, do not proceed with the installation: contact the retailer immediately. The following accessories are supplied inside the packaging, together with the appliance and this instruction manual:

-   
**(5x) Screws and wall plugs to fix the appliance**
-   
**(2x) Extra large brackets for the appliance**  
*(indoor models only)*
-   
**Standard remote controller (MC-601)**  
*(outdoor models only)*
-   
**Connecting cable for the remote**  
*(outdoor models only)*
-   
**Cable clamps and screw to secure the remote**  
*(outdoor models only)*

## Main Components

### Outdoor Models

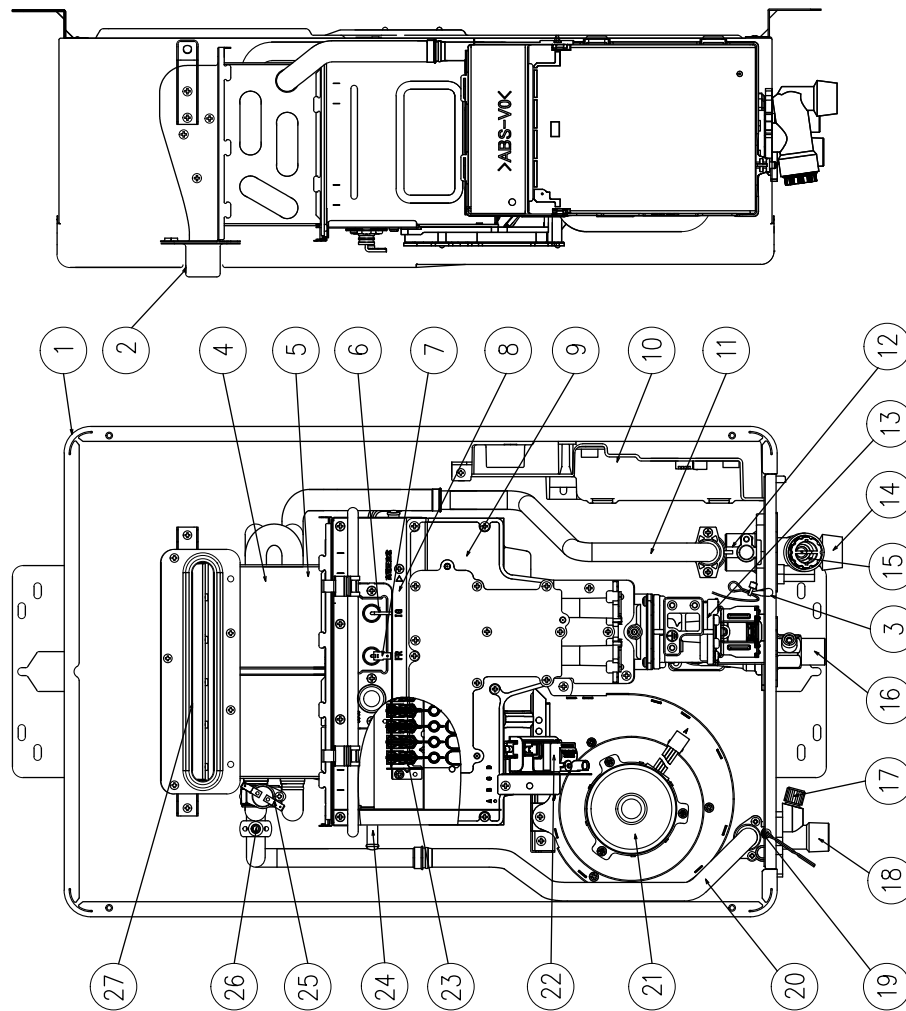

NO.	NAME	NO.	NAME
1	CASING ASS'Y	15	WATER FILTER ASS'Y
2	FRONT PANNEL ASS'Y	16	GAS CONNECTION
3	PREZE PROTECTION THERMOSTAT	17	PRESSURE RELIEF VALVE
4	HEAT EXCHANGER	18	HOT WATER OUTLET
5	THERMAL FUSE	19	OUTGOING WATER THERMISTOR
6	ELECTRODE	20	HOT WATER CONNECTION PIPE
7	FLAME ROD	21	COMBUSTION FAN
8	COMBUSTION ASS'Y	22	IGNITER
9	MANIFOLD ASS'Y	23	MAIN BURNER
10	P.C.B.	24	BYPASS PIPE
11	WATER CONNECTING PIPE	25	OVERHEAT SWITCH
12	WATER FLOW SENSOR	26	OUTGOING WATER THERMISTOR 2
13	GAS CONTROL ASS'Y	27	EXHAUST HEADER
14	WATER INLET	28	WATER FLOW CONTROL DEVICE

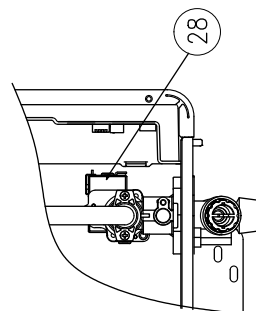

ONLY FOR REU-A1720/1420W

## Indoor Models

NO.	NAME	NO.	NAME
1	CASING ASS'Y	15	WATER FILTER ASS'Y
2	FRONT PANNEL ASS'Y	16	GAS CONNECTION
3	FREIZE PROTECTION THERMISTOR	17	PRESSURE RELIEF VALVE
4	HEAT EXCHANGER	18	HOT WATER OUTLET
5	THERMAL FUSE	19	OUTGOING WATER THERMISTOR
6	ELECTRODE	20	HOT WATER CONNECTION PIPE
7	FLAME ROD	21	COMBUSTION FAN
8	COMBUSTION ASS'Y	22	IGNITER
9	MANIFOLD ASS'Y	23	MAIN BURNER
10	P.C.B.	24	BYPASS PIPE
11	WATER CONNECTING PIPE	25	OVERHEAT SWITCH
12	WATER FLOW SENSOR	26	OUTGOING WATER THERMISTOR 2
13	GAS CONTROL ASS'Y	27	EXHAUST HEADER
14	WATER INLET		

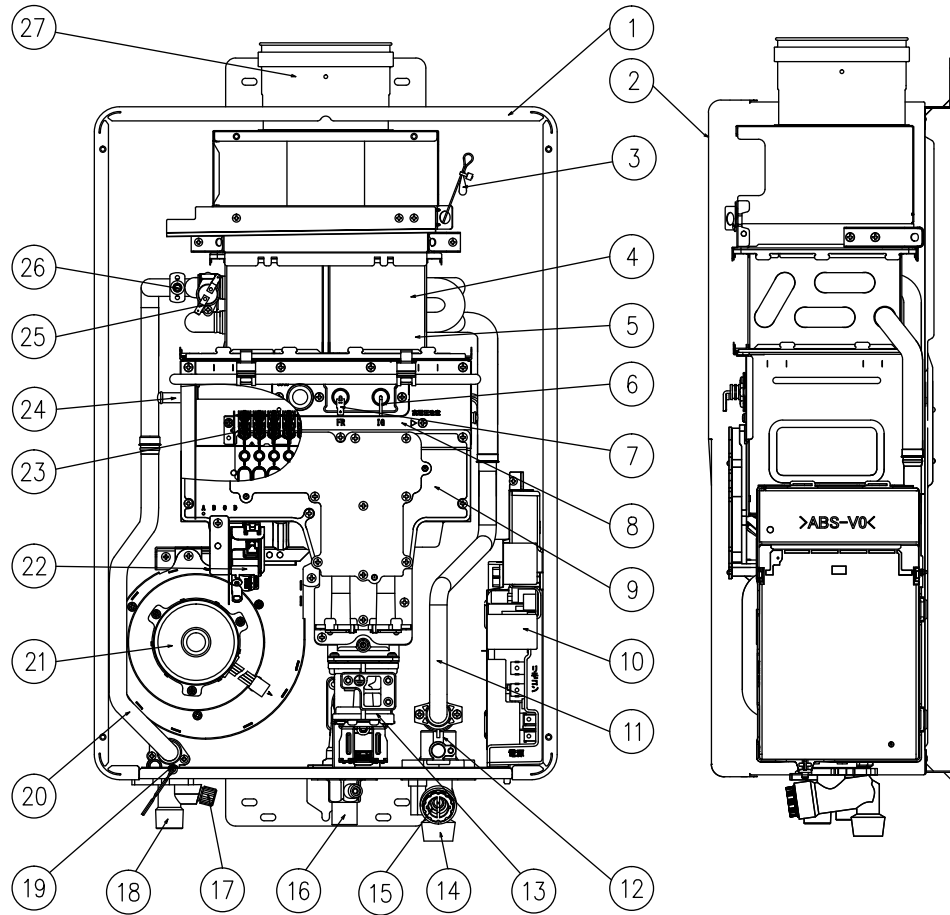

NO.	NAME	NO.	NAME
1	CASING ASS'Y	16	WATER INLET
2	FRONT PANNEL ASS'Y	17	WATER FILTER ASS'Y
3	ORILATER COOLER	18	GAS CONNECTION
4	DRIVER COOLER WATER CONNECTING PIPE	19	PRESSURE RELIEF VALVE
5	HEAT EXCHANGER	20	HOT WATER OUTLET
6	THERMAL FUSE	21	OUTGOING WATER THERMISTOR
7	ELECTRODE	22	HOT WATER CONNECTION PIPE
8	FLAME ROD	23	COMBUSTION FAN
9	COMBUSTION ASS'Y	24	IGNITER
10	MANIFOLD ASS'Y	25	MAIN BURNER
11	P.C.B.	26	OVERHEAT SWITCH
12	WATER CONNECTING PIPE	27	OUTGOING WATER THERMISTOR 2
13	WATER FLOW CONTROL DEVICE	28	DRIVER COOLER HOT WATER CONNECTING PIPE
14	WATER FLOW SENSOR	29	EXHAUST HEADER
15	GAS CONTROL ASS'Y	30	FREIZE PROTECTION THERMISTOR

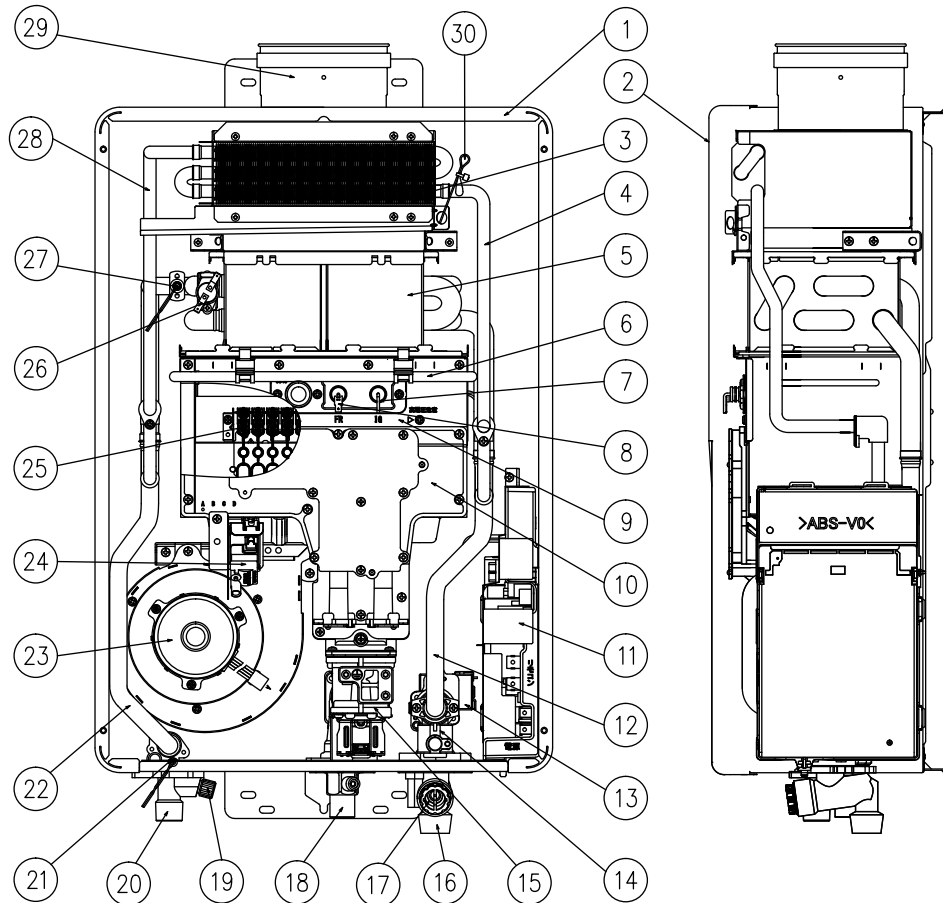



# Dimensions

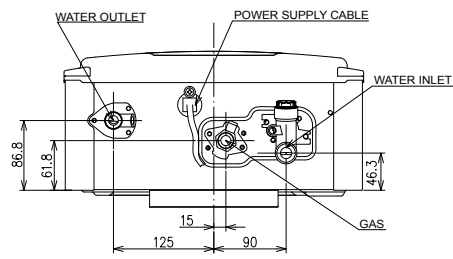
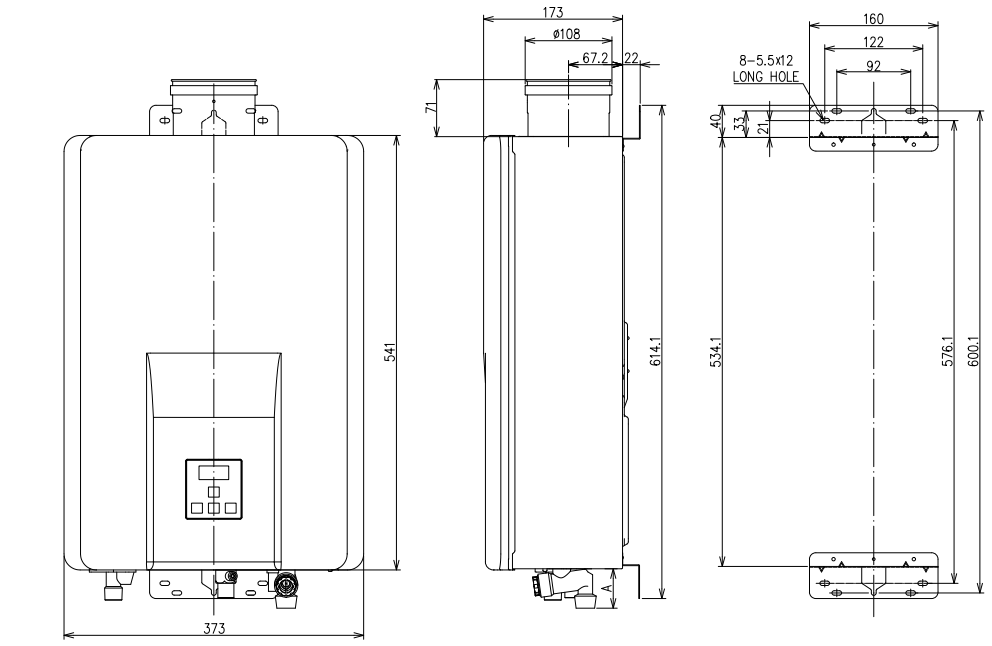

REU-A1111FFU / A1420FFU / A1720FFU

	A	CONNECTIONS
GAS	34.6	R1/2 (15mm)
COLD	47.6	R1/2 (15mm)
HOT	37.6	R1/2 (15mm)

NOTE: dimensions in mm

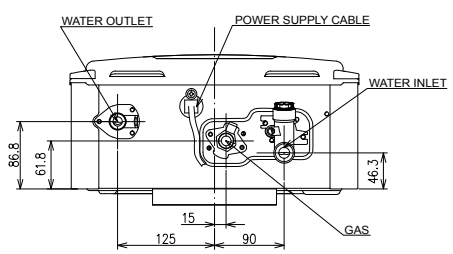
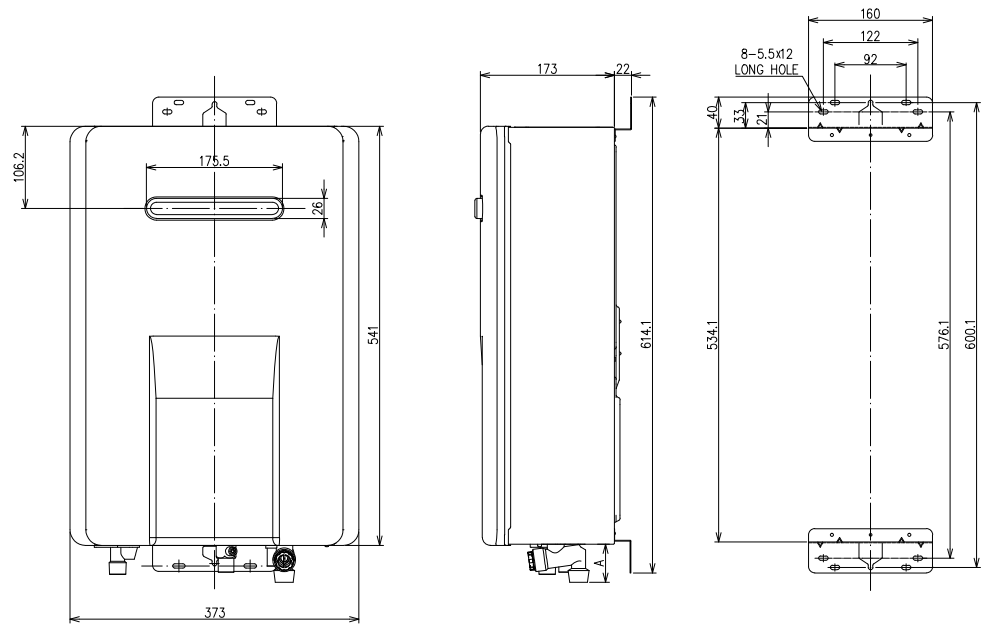

REU-A1111W / A1420W / A1720W

	A	CONNECTIONS
GAS	34.6	R1/2 (15mm)
COLD	47.6	R1/2 (15mm)
HOT	37.6	R1/2 (15mm)

NOTE: dimensions in mm

# General Scheme and Operation Principles

## Operation Principles

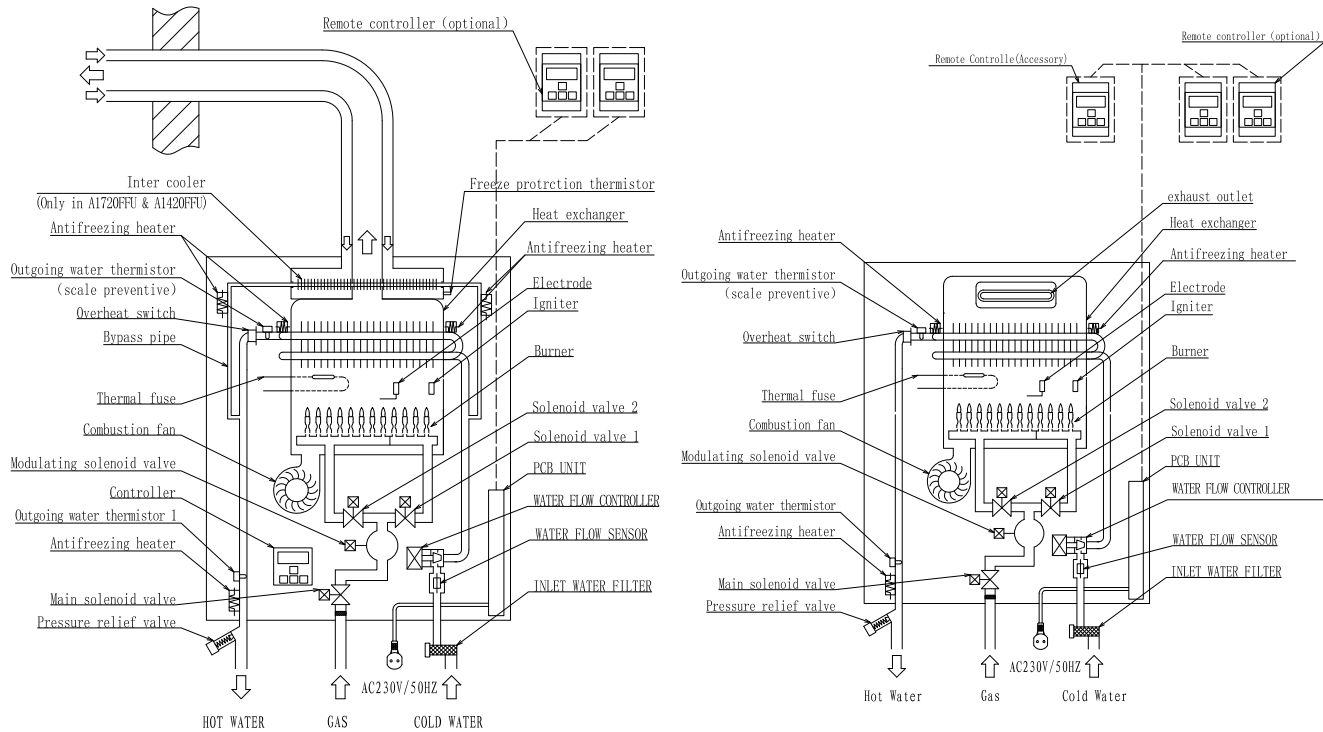

### Ignition

Press the 'On/Off' button on the controller to switch the appliance on; the relative led (models for external), the display and the priority LED will light up. When a hot water tap opens, the flow sensor rotates when water passes and sends a signal to the main control board (PCB). When the PCB detects the flow of water, it compares the temperature detected by the hot water thermistor with the value set by the user. If necessary, the electronic ignition procedure begins by supplying the combustion fan as the first component. Once the ventilation cycle (pre-purge) has been carried out, the gas valves are adjusted and the burner ignited by scintillation.

### Temperature control

When the flame sensor detects the combustion signal (good grounding is required), the appliance starts modulating by controlling gas, air and the water flow rate to heat it accurately to the desired temperature (this control is carried out from hot water thermistor).

### Standby

When the taps are closed, the PCB does not receive any signal from the flow sensor and commands closing of the gas valves, effectively extinguishing the flame to the burner. A forced ventilation cycle is then performed (post-purge).

# Installation

## Clearance

If the unit is installed on a combustible wall such as wood there must be a 35mm gap between the wall and the back of the unit. Brackets are available to space the unit this far off of the wall.

Clearances (mm)	Combustibles	Non Combustibles
Above	300	50
Behind	35	0
Sides	50	15
Front	600	600
Below	300	50
Flue Pipe	20	0



**There must not be any obstacles, even partial, placed on the front of the appliance: this will allow the appliance to work correctly even in strong wind conditions.**

## Water Connection

The sizing and layout of the water pipes must be designed correctly to ensure adequate water flow to the appliance.

Prior to installing the appliance, to avoid invalidating the warranty, it is necessary to clean the pipes to remove any impurities or production residues that could cause the product to malfunction.

The water connections are 1/2" male.

If the water supply pressure (cold water inlet) exceeds 8 bar, a pressure reducer must be installed. In order to achieve maximum flow it is necessary to guarantee a pressure of 0.8bar. The appliance can also work at lower pressures, but the maximum capacity will not be guaranteed. When water is used at high temperatures, the available flow rate decreases and, as a consequence, also the pressure drops in the heat exchanger: a lower pressure at the inlet will therefore be required. Contact Rinnai or your supplier for further instructions.

When connecting the water supply pipes, it is recommended to have a valve and a filter on the cold water inlet union, and a valve on the hot water outlet. Do not connect the valves directly to the water heater's connections, but interpose a flexible connection joint.

If the appliance is supplied with water of poor quality, it is necessary to install an adequate water treatment system (water softener), to limit the scale of limestone and the encrustation on the heat exchanger. The warranty does not cover damages caused by lime-scale. Below are some limit values of substances dissolved in water to respect:

Description	pH	Total dissolved solid (TDS)	Total hardness	Chlorides	Magnesium	Calcium	Sodium	Iron
Max value	6.5-9.0	600mg/litre	150mg/litre	300mg/litre	10mg/litre	20mg/litre	150mg/litre	1mg litre

The hydraulic pipes should be well insulated to optimize energy efficiency and reduce heat losses.

## Gas Connection

Prior to installing the appliance, to avoid invalidating the warranty, it is necessary to clean the gas line to remove any impurities or production residues that could cause the product to malfunction.

Make sure the appliance is set up for the type of gas used.

The gas connection is 1/2" male.

Check that the meter and the gas pipe are adequate to the power of the appliance (including all the appliances connected to the same gas line): the gas network must be designed by qualified professionals and according to current regulations; must provide adequate dynamic pressure based on the rated power of the device. Refer to what reported by the National Standards.

Insufficient gas supply may cause premature damage to the appliance.

The gas supply pressure directly affects the delivered power and can cause problems if it is not correct. If the dimensioning of the gas piping is insufficient, the customer will not be able to enjoy the maximum benefit in terms of performance.

When connecting the gas piping, it is recommended that a valve be set up for emergencies and to facilitate maintenance; do not connect the valve directly to the water heater's connector, but interpose a flexible pipe joint.

**Fuel quality:** the appliance is designed to work with combustible gas without impurities. If this is not the case, an adequate filtration system should be installed upstream of the appliance, in order to restore the necessary quality.

**Storage tanks (LPG):** residues of inert gas (nitrogen, etc.) can become trapped inside the new tanks causing the gas mixture to be depleted. This event can cause malfunctions or anomalies to the device. Due to the composition of the LPG mixture, stratification phenomena of the gas components may occur during the storage period: this may cause a change in the calorific value of the fuel delivered and consequent alteration of the appliance performance.

### Electrical Connection

Connect the appliance to a 230V  $\pm 10\%$  / 50Hz mains.

Do not use gas or hydraulic pipes for grounding.

The electrical safety is guaranteed only when the appliance is correctly earthed and the earthing system has been realized following all the safety prescriptions foreseen by the law.

Make sure that the electrical system is adequate for the maximum absorbed power and is equipped with an omnipolar circuit breaker with class III over-voltage category.

The appliance is supplied with an electric cable already fitted with a plug. In case of replacement, contact a qualified technician and use only original Rinnai spare parts to avoid invalidating the warranty.

The use of plug adapters or multiple sockets is not permitted.

The appliance meets the requirements of the European directives:

- "low voltage" directive;
- "electromagnetic compatibility" directive.

The appliances are IPx5D class (outdoor models) and IPx4D class (indoor models).

### Control Board Dip-switch Setting

Incorrect setting of the micro-switches on the main electronic board (PCB) can cause the unit to malfunction.



The factory setting of all PCB micro switches is 'OFF' (to the left).

**NOTE** Indoor models only: when installing a 'long' flue system (equivalent length >5m) the dip-switches **SW1** and **SW3** must be set in the 'ON' position (to the right).

Indoor models only: when installing the flue diverter the dip-switches **SW1** and **SW3** must be set in the 'ON' position (to the right).

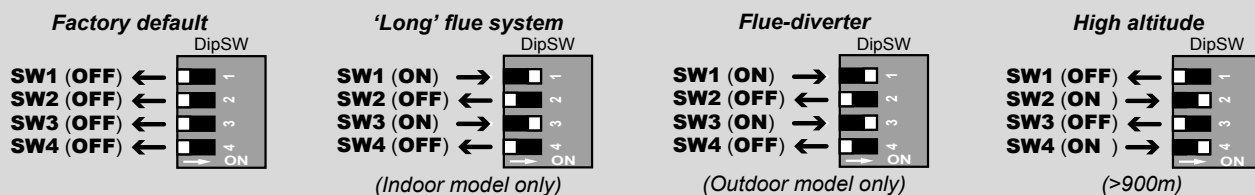

When installing the appliance in high altitude areas (> 900m) the dip-switches **SW2** and **SW4** must be set in the 'ON' position (to the right).

## Flue System

The flue system must be carried out by competent personnel, authorized according to the law, following the manufacturer's instructions and respecting the provisions of the law and the technical regulations in force.

Make sure that the flue terminal is always free from obstructions and external obstacles and that it is protected to avoid contact burns.

The OUTDOOR model is approved for operation without exhaust system: it is NOT allowed to connect ANY flue system to the exhaust of this model.

The INDOOR model must be installed by ALWAYS connecting a Rinnai approved flue system: they cannot be operated without having correctly installed the flue system. The indoor unit's exhaust system is considered as part of the appliance: it is only possible to install certified and tested exhaust systems in combination with the appliance.

The flue system type must correspond to one of the many mentioned on the data plate label (located on the side of the appliance). Rinnai provides a specific inlet/exhaust system for the appliance. Detailed installation instructions are supplied with the flue elements. For more information contact Rinnai.

**Coaxial flue:** in the upper part, the appliance is provided with a coaxial connection (Ø60/100mm) for the intake of combustion air (external pipe) and for the expulsion of combustion products (central pipe). It is possible to connect pipes to extend the flue system. The ducts (coaxial extensions and curves) must have a diameter not inferior to the initial connection, be made of materials suitable for the appliance's flue gas temperatures and have sealed 'male/female' fittings.

**Coaxial length:** the max equivalent length for the models Infinity 17i is 6.5m for the 11i, the max length is 2.5m.

The use of each 90° bend is equivalent to 0.5m: subtract this value to the max equivalent length for each 90° bend used.

The maximum number of 90° bends that can be used for Infinity 17i models is three; one for the One 11i model.

Any combination of bends and extensions that comply with the maximum equivalent length and the maximum number of 90° bends is allowed. There is no minimum required distance for the flue system.

**Condensate:** if the length of the exhaust system exceeds 1.5m, to prevent damages to the appliance, it is recommended to install a siphon kit to remove any potential condensate.

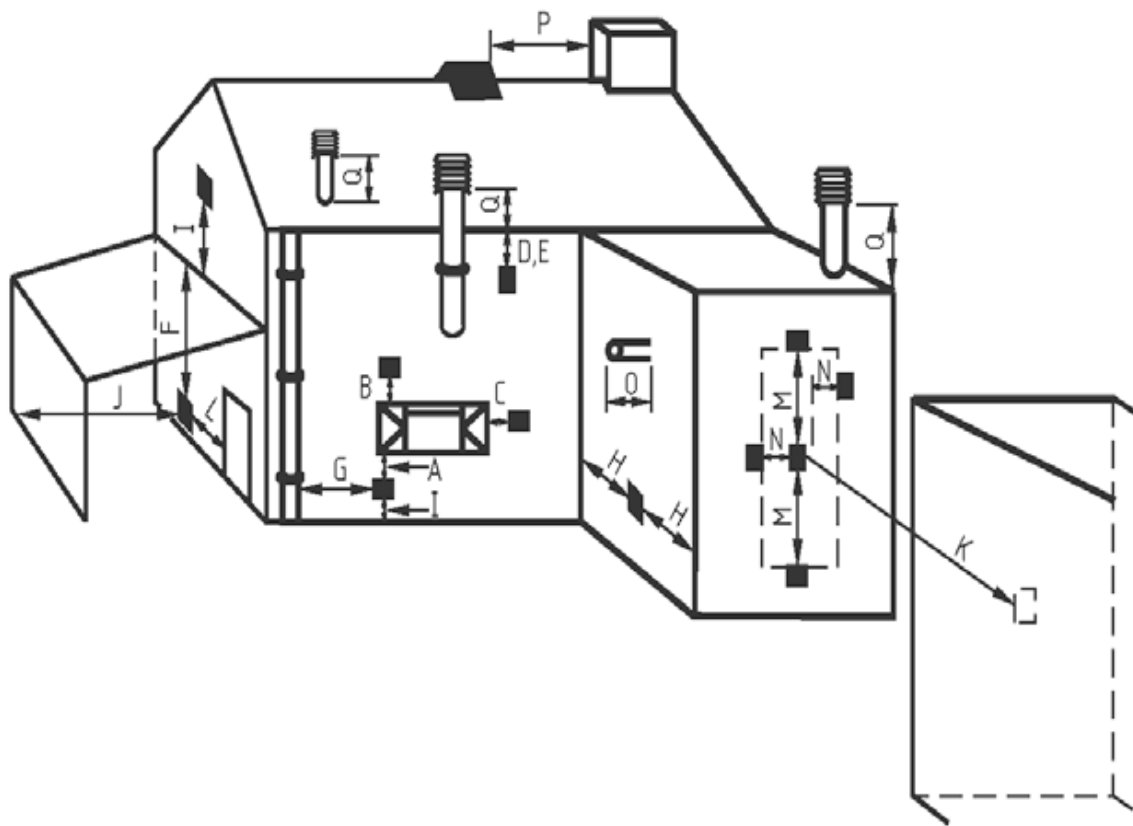

Symbol	Terminal Position	Dimensions
<b>A</b>	Directly below an opening, air brick, opening windows, etc	<b>300mm</b>
<b>B</b>	Above an opening, air brick, opening window, etc.	<b>300mm</b>
<b>C</b>	Horizontally to an opening, air brick, opening window, etc.	<b>300mm</b>
<b>D</b>	Below plastic gutters, soil pipes, drain pipes, etc.	<b>75mm</b>
<b>E</b>	Below eaves	<b>200mm</b>
<b>F</b>	Below balconies or car port roof	<b>200mm</b>
<b>G</b>	From vertical drain pipe or soil pipe	<b>150mm</b>
<b>H</b>	From and internal or external corner	<b>300mm</b>
<b>I</b>	Above ground, roof or balcony level	<b>300mm</b>
<b>J</b>	From surface facing the terminal	<b>600mm</b>
<b>K</b>	From terminal facing terminal	<b>1200mm</b>
<b>L</b>	From opening in the car port (eg door, window etc) into the dwelling	<b>1200mm</b>
<b>M</b>	Vertically from terminal on the same wall	<b>1500mm</b>
<b>N</b>	Horizontally from terminal on the same wall	<b>300mm</b>
<b>O</b>	From the wall on which the terminal is mounted	<b>N/A</b>
<b>P</b>	From a vertical structure on the roof	<b>0</b>
<b>Q</b>	Above intersection with the roof	<b>300mm</b>

BS 5440

# Remote Controller

A standard remote controller (MC-601) is supplied as a standard together with any outdoor model water heater. The indoor models are supplied with a non-removable controller on the front panel.

However, it is possible to add up to three additional remote controllers on both product ranges (outdoor and indoor), to be able to adjust the temperature of the hot water from different rooms in your home.

When more remote controllers are connected to the unit, only one of them can be set as the main or the 'Master'. Normally it is selected, as 'Master' controller, the one located in the kitchen and it is set to a maximum temperature of 55°C. It is always possible to raise this limit but it is not strictly necessary for normal domestic use: this temperature increase leads to a higher gas consumption and a potential risk from scalding.

The additional controllers connected are recognized as 'Sub' controllers (secondary); they are generally intended for the use in environments other than the kitchen: bathroom, laundry, etc. The maximum temperature they are allowed to select is electronically limited to 50°C: this is to reduce the risk of hot water burns as much as possible.

Instructions for the installation of the remote controller are given below.

## General Information

It is possible to connect to a water heater to a maximum number of four controllers. It is possible to install Standard remotes (MC-601) or any combination of Standard, Deluxe 'kitchen' (MC-100V) or Deluxe 'bathroom' (MB-100V) remotes respectful of the following rules:

- A max of four controllers can be fitted.
- Only one 'Master' controller can be installed: a Deluxe 'kitchen' (MC-100V) or a Standard (MC-601).



**By connecting a Deluxe 'kitchen' control, this is automatically recognized as 'Master' (this is an unchangeable factory setting).**

- A maximum of two Deluxe 'bathroom' (BC-100V) controls can be installed.
- The fourth remote control must be of the Standard type (MC-601).

To learn more about the Deluxe remote controls, contact Rinnai or visit: [www.rinnaiuk.com](http://www.rinnaiuk.com).

## Location



- Do not install water controllers near a heat source, such as a cook top, stove or oven. Heat, steam, smoke and hot oil may cause damage.
- Do not install water controllers outdoors unless protection from water/dust ingress and sunlight are provided.
- The water controller set as the master water controller must not be installed in a bathroom.
- Do not install water controllers in direct sunlight.
- Do not install water controllers against a metal wall unless the wall is earthed.
- Water controllers must not be installed where chemicals such as benzene, alcohol, turpentine, hydrogen sulphide, ammonia, chlorine or other similar chemicals are in use.
- The Water controller is a water resistant device, however excessive exposure to water may result in damage to the water controller. Durability is improved when positioned outside the shower recess.
- Avoid direct exposure to water or steam as these conditions may cause a malfunction.
- Water controllers must be installed in shaded and clean locations.
- They should be fitted out of reach of children (suggested height from floor to be at least 1.5m). Water controllers must be installed at least 40cm above the highest part of a sink, basin or bath.
- When cleaning your water controller use only a damp cloth and a mild detergent.

## Communication cable

Wired remote controllers operate at an extra low voltage (12 Volts DC) which is supplied from the water heater. A 10m long communication cable is supplied for connection to the water heater. It is possible to prolong the communication cable by using a similar one, up to a total max length of 50m. When connecting the cables to remote controller the polarity is not important: either colour wire can be connected to either terminal.

It is not recommended to install the communication cable near by house electric cables: interference may easily happen causing system malfunctions. In these cases we recommend to use proper shielded cables.

The installation of the connection cable is simplified by the presence of unique special connectors both on the electronic board side and on the remote control side:

### Installation procedure (appliance side):



**Do not attempt to connect cables to the water heater unless the electric power is switched 'off' otherwise damage to electrical components may occur.**

1. Isolate the electric power supply by switching the power point off and removing the power plug of the water heater from the electric power socket.
2. Remove the front panel: remove the grey plastic side strips and unscrew the 4 fixing screws of the panel;
3. Pass sufficient cable through the hole in the casing (Fig. 1); connect the terminal end to the electronic board and fix it to the body © (Fig. 2);
4. Connect the other terminal of the cable (A) to the remote control connector (B) (Fig. 3)
5. Fix the front panel back.

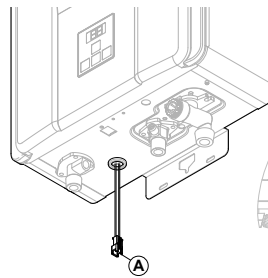

Fig. 1

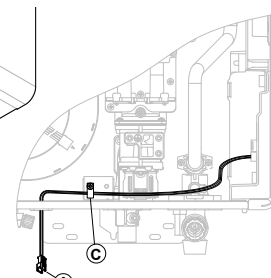

Fig. 2

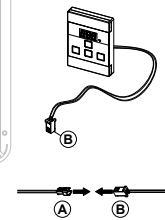

Fig. 3

When connecting more remote controllers it is necessary to cut the connectors (A) and (B), and to use a common electrical terminal block (optional)



**The additional remote controls must be electrically connected in parallel: a series connection causes the system to malfunction and can damage the components of the appliance.**

### Standard Remote Controller (MC-601) Installation

1. Determine the most suitable position.
2. Mark and drill 3 holes (mounting and cable access) for remote controller dimensions.

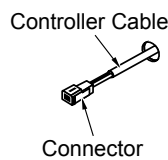
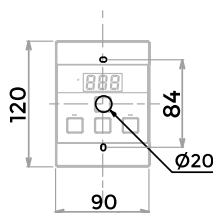

Fig. 1

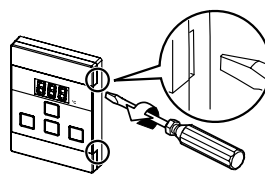

Fig. 2

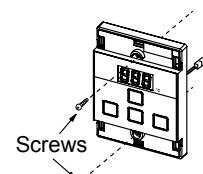

Fig. 3

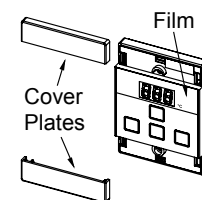

Fig. 4

3. When running cable through the access hole ensure the connector end of the cable is located nearest to the remote controller (Fig. 1).
4. Carefully remove the cover plates from the remote controller, using a screw driver (Fig. 2).
5. Connect the cable to the remote controller. Feed any excess cable lengths into the wall cavity to avoid the pinching of cables between the wall and the remote controller.
6. Fix the remote controller to the wall using the appropriate fixings (Fig. 3).
7. Remove protective film from the controller face and replace the cover plates (Fig. 4).



## Control Panel Programming



QUESTION

### 1 Are there four control panels connected (control panel + remote controllers)?

**NO:** If there are up to 3 control panels connected, go to question 2.

**YES:** You need to activate the fourth controller as follows:

**STEP 1:** On the 'Master' controller only, press and hold the 'Priority' and 'On/Off' buttons simultaneously (see Fig. 1) until a 'beep' is heard (approximately 5 seconds).

**STEP 2:** Check that the display on all four controllers is lit and displaying a temperature when 'switched on'.

If any one of the controllers displays two dashes (see Fig. 2) repeat from STEP 1.

This completes the activation procedure for the fourth controller, you may ignore Question 2.

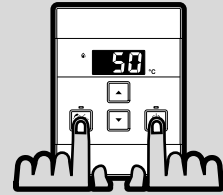

Fig. 1



Fig. 2



QUESTION

### 2 Do you want hot water temperature limited to 50°C?

**SI:** No further action required.

**NO:** You need to unlock the 'Master' remote to achieve high temperatures.

**STEP 1:** On the 'Master' controller only, press and hold the 'Priority' and 'On/Off' buttons simultaneously (Fig. 3) until a 'beep' is heard (approximately 5 seconds).

**STEP 2:** When the 'Master' controller is switched on, it should be possible to select temperatures higher than 50°C. If not, repeat STEP 1.

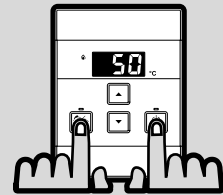

Fig. 3



NOTE

If the 'Master' controller is changed to a new one, repeat the procedure from 'STEP 1' (question 2) on the new controller.

If the 'Master' controller is switched with a new controller previously installed (e.g. the one in the laundry), repeat the procedure from 'STEP 1' (question 2) on both controllers.

## Commissioning

- Make sure the water heater is not subject to corrosive compounds in the air.
- Check the water supply does not contain chemicals or exceeds any of the limits on page 23 paying particular attention to the total hardness. Failure to provide adequate protection can invalidate the warranty.
- Check the clearances for the water heater are met
- Check the clearances for the flue comply with current regulations.
- For indoor models: ensure you have used the correct flueing products for the model installed and that you have completely followed the flueing manufacturer's installation instructions and these installation instructions.
- For indoor models: verify that the vent system does not exceed the maximum length.
- Ensure that an approved gas isolation valve has been installed in the immediate vicinity of the water heater.
- Ensure that suitable isolation valves have been installed on the hot and cold pipework to and from the water heater.
- Before final connection of the water heater purge gas, hot water and cold water supply lines. Debris or swarf in either the gas or water supplies may cause damage.
- Clean the inlet water filter ensuring the isolation valves are closed before you do so.
- Turn on gas and cold water supplies and test for any leaks.
- Ensure that hot and cold water lines are not crossed to the unit.



**Remove the front panel and confirm the control board dip-switch settings are set to the correct positions as required:**

- factory default;
- correct flue system extension (only indoor models);

**Fix the front panel back.**

- Isolate gas supply. Remove test point screw located on the gas inlet connection and attach pressure gauge.
- Turn the power 'on' at the power point socket and turn on gas.
- If controllers are fitted, ensure they are 'ON', with the maximum delivery temperature selected and open all available hot water outlets.
- If controllers are not fitted, simply open all available hot water outlets.



**Ensure building occupants do not have access to hot water outlets during this procedure.**

- Operate all other gas appliances connected to the same gas line (boiler, cook top, etc..) at their maximum gas rate.
- With all gas appliances in operation at maximum gas rate, the pressure should read between 20mbar on natural gas. On LPG the pressure should be 30mbar/37mbar propane. If the pressure is lower, the gas supply is inadequate and the appliance will not operate to specification. It is the Installers responsibility to check the gas meter, service regulator and pipe work for correct operation/sizing and rectify as required.



**The gas regulator on the appliance is electronically controlled and factory pre-set: it does not need any adjustment during installation.**

**Prior to making any changes, contact Rinnai.**

- Fully complete the Benchmark Commissioning form in this manual. It is important this is fully completed for warranty purposes
- Close any hot water outlets opened.
- Inspect and clean the strainer located on the cold water inlet connection. This procedure may need to be repeated to ensure the strainer remains clear, especially on new installations.
- If remote controllers are fitted, it is necessary to test their operation through the complete range of functions.
- Confirm the hot water delivery temperature using a thermometer.
- If 'Sub' controllers are fitted, ensure temperatures exceeding 50°C cannot be selected.
- After testing is completed, explain to the end user the functions and operation of the water heater and the controllers.
- Remind the customer to complete the warranty card and forward it to Rinnai.
- Inform customer on use of an adequate lime scale protection system to prevent damages to heat exchanger if one is not already installed.
- Leave the manual to customer.
- If the water heater is not needed for immediate use, then drain the water from the heat exchanger.

## GAS FIRED CONTINUOUS FLOW WATER HEATER COMMISSIONING CHECKLIST

This Commissioning Checklist is to be completed in full by the competent person who commissioned the water heater as a means of demonstrating compliance with the appropriate Building Regulations and then handed to the customer to keep for future reference

Failure to install and commission according to the manufacturer's instructions and complete this Benchmark Commissioning Checklist will invalidate the warranty. This does not affect the customer's statutory rights.

Customer name:		Telephone number:	
Address:			
Water Heater Make & Model:			
Serial Number:			
Commissioned by (PRINT NAME):		Gas Safe Register Number:	
Company name:		Telephone number:	
Company address:			
		Commissioning date:	
<b>To be completed by the customer on receipt of a Building Regulations Compliance Certificate*:</b>			
Building Regulations Notification Number (if applicable)			
<b>CONTROLS</b>			
Is there a separate temperature control fitted	Yes		No
Have they been explained to the customer	Yes		No
Has the Appliance been set to the required MAX temp.	Yes		No
If NO has the Appliance been set to the required temp.	Yes		No
<b>SYSTEM</b>			
Is there a filter on the incoming mains	Yes		No
Is the system on a secondary return	Yes		No
Has an unvented kit been installed	Yes		No
If yes please record Safety Valve Size and rating	Size	Rating	
Does the discharge pipe comply with current building regulations			Yes
Please record location of Pressure Reducing Valve			
Pressure Reducing Valve Setting			
Expansion Vessel Size			
Expansion Vessel Charge Pressure			
Has the system been installed with a storage vessel	Yes		No
<b>DOMESTIC HOT WATER MODE</b>			
Gas Rate at High Fire	m <sup>3</sup> /hr	ft <sup>3</sup> /hr	
Burner Pressure	Lo	mbar	Hi
Inlet Pressure Dynamic at Hi Fire and all other appliances running	mbar		
Inlet water temp			°C
Water Heater Set Temperature			°C
Maximum Flow Rate Achieved	L/min		
Is the installation in a hard water area (above 150mg/L)	Yes		No
If Yes What Type of Scale Reducer has been Fitted			
Hot Water checked at all outlets	Yes	Temp	°C
<b>FLUEING</b>			
What type of water heater is fitted	Internal	External	
EXTERNAL is the unit mounted fully outside	Yes		No
If NO explain in detail where the appliance is mounted			
INTERNAL does the flueing comply with current standards			
Yes		No	
If the flueing to manufacturers instructions			
Yes		No	
<b>CONDENSING WATER HEATERS ONLY</b>			
Has the condensate drain has been installed as per manufacturers instructions and/or BS5446/BS6798	Yes		No
<b>FULL INSTALLATION</b>			
Record the following:	At max rate: CO ppm	and	CO/CO2 Ratio
	At min. Rate: (where possible) CO ppm	and	CO/CO2 Ratio
Does the hot water system fully comply with the appropriate Building Regulations			Yes
The water heater and associated products have been installed and commissioned in accordance with all manufacturers instructions			Yes
The full operation of the water heater and any controls have been demonstrated to and understood by the customer			Yes
The manufacturers literature including Benchmark Checklist and Service Record, has been explained and left with the customer			Yes
Commissioning Engineer's Signature			
Customer's Signature			
(To confirm satisfactory demonstration and receipt of manufacturer's literature)			

\*All installations in England and Wales must be notified to Local Authority Building Control (LABC) either directly or through a Competent Persons Scheme. A Building Regulations Compliance Certificate will then be issued to the customer.



© Heating and Hotwater Industry Council (HHIC)

www.centralheating.co.uk

# MAINTENANCE INSTRUCTIONS

## PCB Interface, Layout and Functions

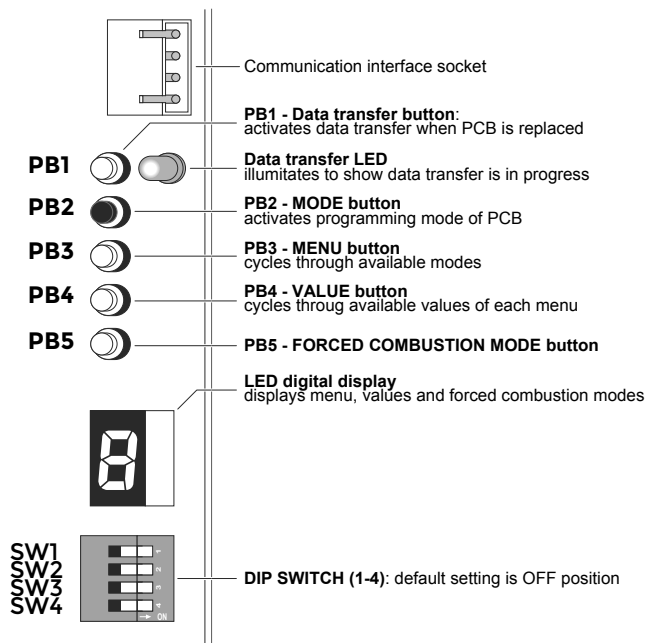

### Operation of the PCB interface

To enter into the PCB's programming mode press **PB2** until the LED digital display shows "1" (Gas type); the current set value of "menu 1" will be displayed shortly afterwards (the possible values of "menu 1" are: "A", "b", "C" or "d").

To modify the value of the menu press **PB4**: each press of the button will select the next available value.

To switch to a different menu, press **PB3**: each press of the button will select the next available menu.

To exit from the programming mode press **PB2** until the LED display goes blank.

By pressing **PB5** the display shows "L" (forced low combustion mode): by pressing **PB3** or **PB4** it is possible to increase or reduce the min gas pressure.

Pressing **PB5** again the display shows "H" (forced high combustion mode): by pressing **PB3** or **PB4** it is possible to increase or reduce the max gas pressure.

### Menu and values

Nr.	Menu	Value						
		A	B	C	D	E	F	H
1	Gas type	G31	G30	G20	G230	G25		
2	Model selection <sup>1</sup>	17 lit	14 lit	11 lit				
3	Max temperature <sup>2</sup>	55°C	65°C	60°C	50°C	42°C	40°C	
4	Warm water inlet <sup>3</sup>	+3°C	+6°C					
5	Auto reset <sup>4</sup>	No	Yes					
6	Temp. adjustment <sup>5</sup>	0°C	+1°C	+2°C	+3°C			
7	Model type <sup>1</sup>	Outdoor	Indoor					

<sup>1</sup> This setting is programmed in factory and cannot be changed.

<sup>2</sup> This setting can modify the max temperature selection of the water heater; default setting is 55°C.

<sup>3</sup> This setting can modify normal operation of water heater to keep heating water until outgoing temperature is "Tset+6°C"; default setting is +3°C.

<sup>4</sup> When water controller is switched on and the "auto reset" function is activated (b), the water heater automatically switches on and auto sets at temperature selected before the black-out happens.

<sup>5</sup> This setting can increase the hot water temperature delivery in case of heat losses due to lack of insulation of water pipes; default setting is 0°C: temperature set on water controller is the delivered temperature.

## Dip switch SW(4p) settings

The switches of the control board are set to **OFF** (left position) as default setting. When a 'long' flue system (>5m) is connected (indoor models only) the installer must set switches SW1 and SW3 to **ON** (right position). When a sideways flue diverter is fitted (outdoor models only) the installer must set switches SW1 and SW3 to **ON** (right position). When the appliance is installed in high altitude areas (>900m; <1800m) the installer must set switches SW2 and SW4 to **ON** (right position).

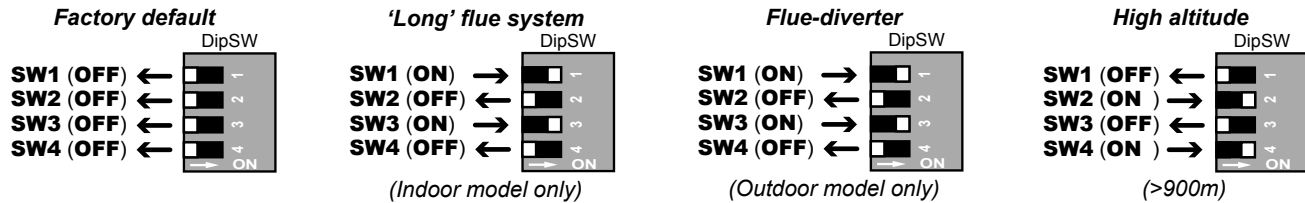

## Data Transfer Between PCB's

If a new PCB needs replacing, you can transfer data (gas type, model type, gas pressure and error history) from the existing PCB to the new one by doing the following:

1. Check the current settings and note them on a piece of paper.
2. Adjust the dip switch settings on the new PCB according to the old one.
3. Unplug the power supply and remove the existing PCB.
4. Fit the new PCB and connect all the wiring harnesses
5. Ensure it is earthed correctly.
6. Connect the new board to the old board using the data transfer cable provided with the new PCB.
7. Reconnect the power supply and push PB1 button of the new PCB.
8. The LED goes green: it means that the data transfer was successful. This will stay green for five minutes or until the PB1 button is pressed again.
9. If the data transfer is unsuccessful the LED will start flashing.
10. Turn off the power supply and remove the data transfer cable.

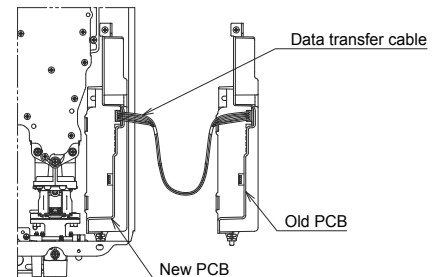

If the data transfer was not successful set the PCB manually according to the settings copied at the beginning of this procedure. If manually set, the max and min gas operating pressures must be checked. Contact Rinnai UK if any assistance is required.

## Gas Conversion Procedure



**Only qualified professionals are authorized to carry out the operations described.**

**The product warranty does not cover any alterations due to non-qualified personnel.**

**The min and max gas operating pressures are factory pre-set: under normal circumstances any adjustment is not required during installation.**

The gas conversion procedure is made of three steps:

- gas manifold change;
  - selection of the different type of gas on PCB;
  - verify and adjustment of the min and max gas pressures.
1. Turn off the gas and power and remove the front cover. Make sure that dip switches SW1 and SW3 on PCB are set to 'Off' position (ignore SW2 and SW4 set position).
  2. Disconnect the igniter from manifold ("I" - Fig.1).
  3. Replace the gas manifold with the new suitable component (the manifold is fastened by the screws indicated with "Y" - Fig.1). Manifold's gas type can be checked by the letter marked as in Fig.2.
  4. Turn on the power and check the gas type on PCB entering in the programming mode by pressing PB2 until the LED display of PCB shows 1: the current gas type will be displayed shortly afterwards.
  5. Press PB4 to modify gas type accordingly to new gas type: A=Propane, b=LPG, C=NG, d=air/propane.
  6. Exit programming mode pressing PB2 until the LED digital display goes blank.
  7. Attach the digital manometer to the test point located on the gas valve (Fig.3).
  8. Turn on the gas. If remote controllers are fitted, turn the unit on at the kitchen controller: select the maximum delivery temperature and fully open all hot water taps including the shower. Let the water run for a short period to allow the flow rate and temperature to stabilise. Ensure the building occupants do not have access to the hot water outlets during this procedure.
  9. Set the water heater to forced low combustion by pressing PB5 until the LED display shows "L". Check the gas pressure at manometer and adjust it if required: to raise the gas pressure press PB3; to lower it press PB4.
  10. Set the water heater to forced high combustion by pressing PB5 until the LED display shows "H". Check the gas pressure at manometer and adjust it if required: to raise the gas pressure press PB3; to lower it press PB4.
  11. Set the water heater back to normal combustion by pressing PB5 until the LED display goes blank.
  12. Close the hot water taps. Remove the manometer and replace the test point screw.
  13. Operate and check for gas leaks at the test point. Set dip switches SW1 and SW3 on PCB to original position.
  14. Fix the front cover of the appliance and update the data-plate to the new gas type

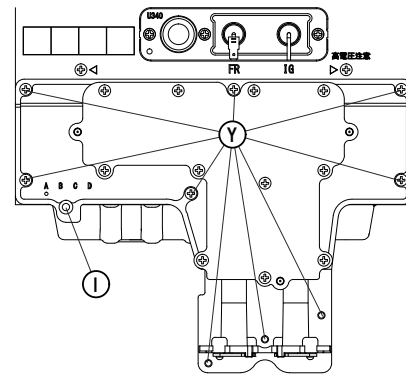

Fig.1

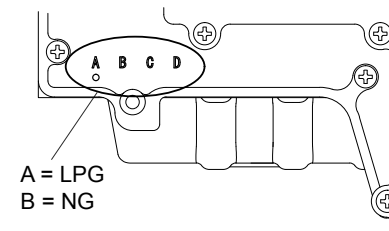

Fig.2

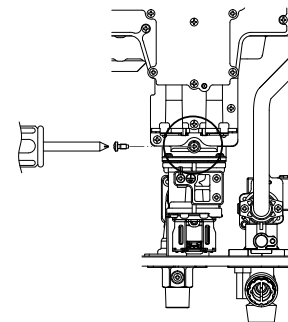

Fig.3



Gas pressures must be adjusted when front panel is removed and combustion mode is forced.

When measuring combustion or gas consumption, be sure, instead, that the water heater operates in normal mode, front panel is closed and

- (Max) remote controller set 60°C + max flow rate (full open shower and taps)
- (Min) remote controller set 37°C + 3l/min flow rate.

## Gas Pressures

11i - REU-A1111FFU-E(UK)				
Gas Type	G20 / Nat Gas	G230 / Air Propane	G30 / Butane	G31 / Propane
Low Fire Setting	1.83 mbar	2.15 mbar	2.43 mbar	2.43 mbar
High Fire Setting	4.97 mbar	6.22 mbar	6.65 mbar	7.53 mbar
17i - REU-A1720FFU-E(UK)				
Low Fire Setting	1.92 mbar	2.15 mbar	2.68 mbar	2.68 mbar
High Fire Setting	10.85 mbar	13.55 mbar	13.24 mbar	15.95 mbar
17E REU-A1720W-E(UK)				
Low Fire Setting	1.58 mbar	1.89 mbar	2.29 mbar	2.29 mbar
High Fire Setting	9.0 mbar	11.57 mbar	11.6 mbar	15.1 mbar

## Water Flow Chart

Water pressure-flow diagram:

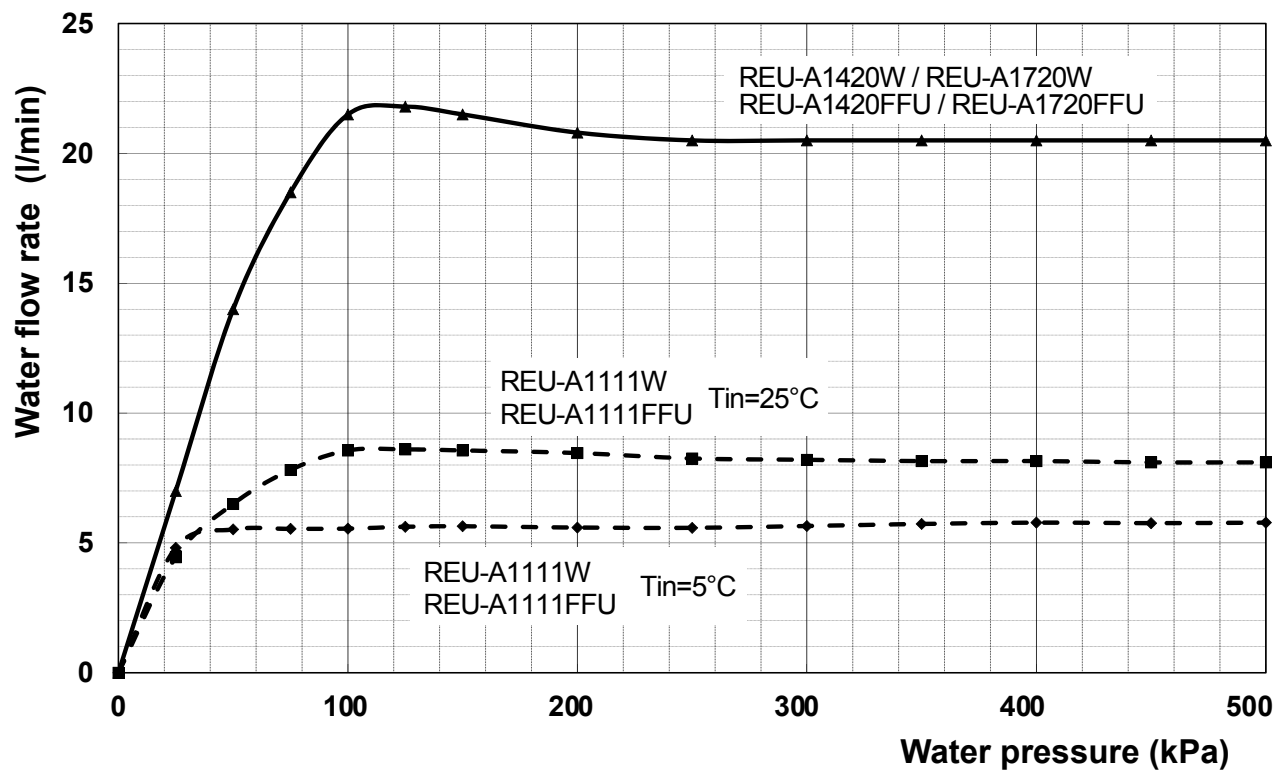

# Flow Chart

## OPERATIONAL FLOW CHART

### OPERATION

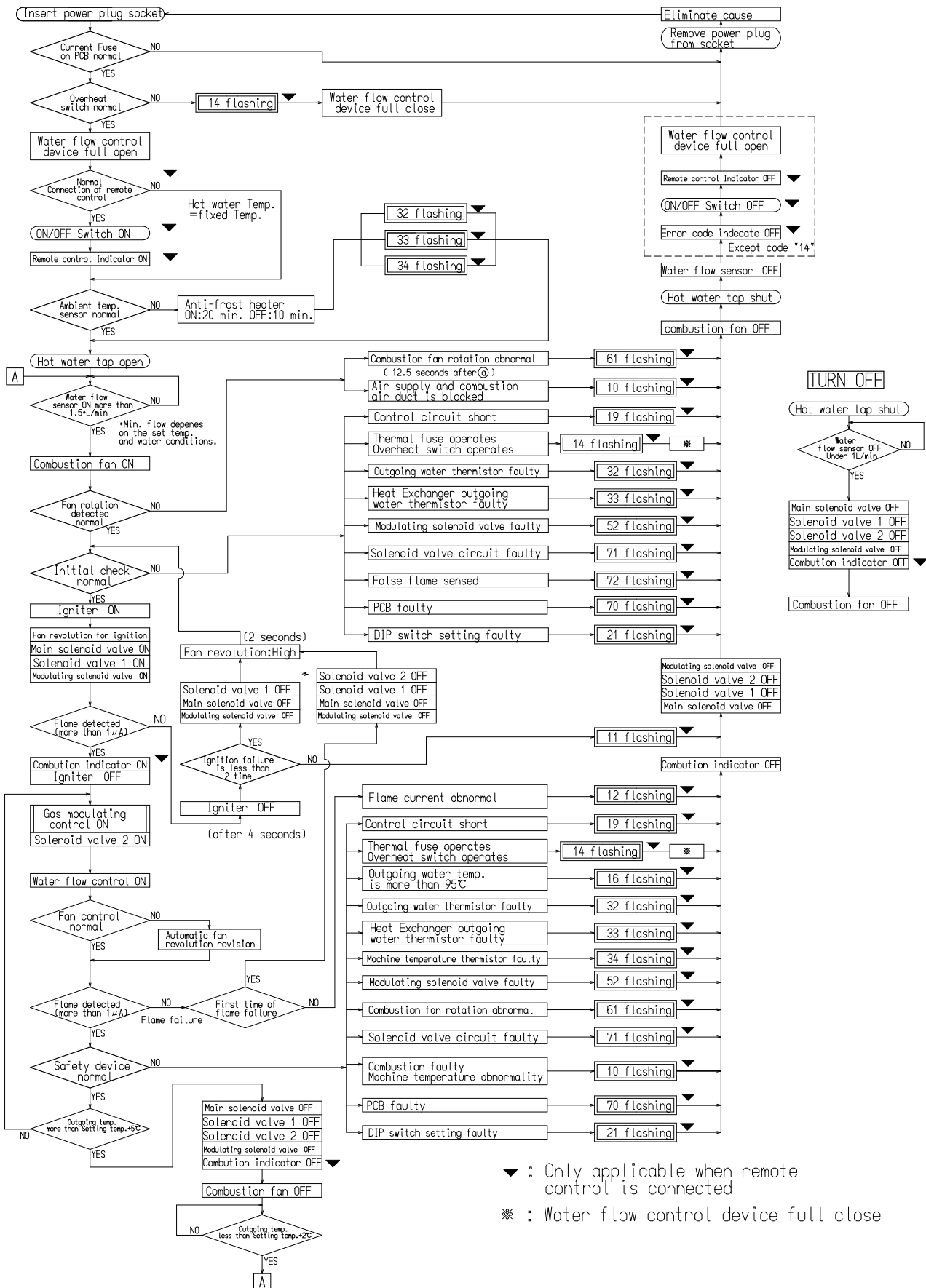



# Wiring Diagram and Diagnostic Readings

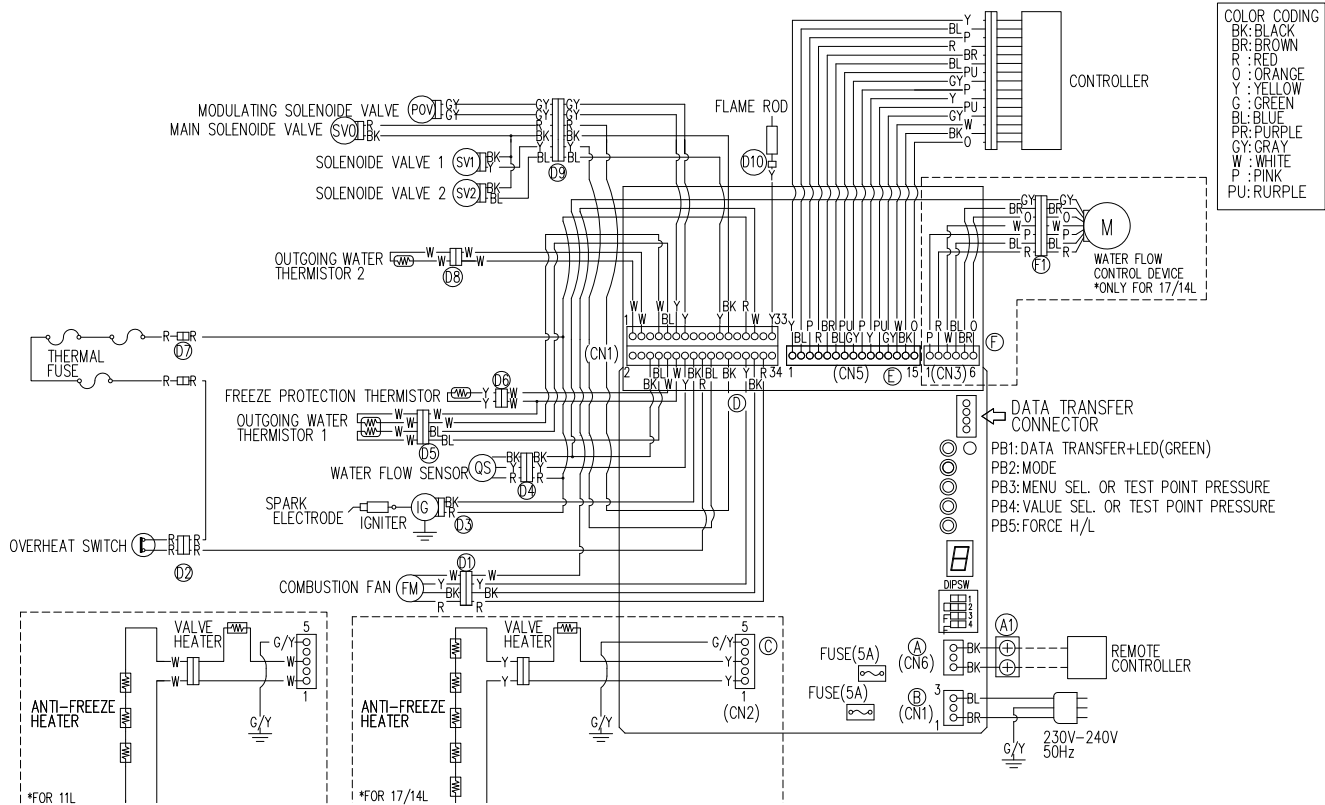

COMPONENT	MEASUREMENT POINT		RANGE OF VALUE
	CN/Con.re	WIRE COLOUR	
MAIN POWER CODE	<b>B</b>	BR-BL	AC198-264V
REMOTE CONTROLLER	<b>A1</b>	BK-BK	DC11-13V
IGNITER	<b>D3</b>	R-BK	DC11-13V (DURING IGNITION)
FLAME ROD	<b>D10</b>	Y-BODY (GND)	OVER DC5V (DURING OPERATION)
		Y-FLAME ROD	OVER 1µA (DURING OPERATION)
THERMAL FUSE	<b>D7</b>	R-R	BELOW DC1V,BELOW 1Ω
OVERHEAT SWITCH	<b>D2</b>	R-R	BELOW DC1V,BELOW 1Ω
MODULATING SOLENOID VALVE	<b>D9</b>	GY-GY	DC2-17V / 10-20Ω
MAIN SOLENOID VALVE		R-BK	DC8-13.5V / 15-25Ω
SOLENOID VALVE 1	<b>D8</b>	BL-BK	DC8-13.5V /20-30Ω
SOLENOID VALVE 2		Y-BK	
OUTGOING WATER TH1	<b>D5</b>	W-W (No. 1 , 2)	15°C : 11.4-14.0kΩ
OUTGOING WATER TH2		W-W (No. 3, 4)	30°C : 6.4-7.8kΩ 45°C : 3.6-4.5kΩ
HEAT EXCHANGER OUTGOING WATER TH	<b>D11</b>	W-W	60°C : 2.2-2.7kΩ 100°C : 0.6-0.8kΩ
FREEZE PROTECTION THERMISTOR	<b>D6</b>	Y-Y	0°C : 38-43kΩ 10°C : 22-26kΩ 20°C : 14-17kΩ
WATER FLOW SENSOR	<b>D4</b>	R-BK (GND)	DC11-13V
		Y-BK (GND)	DC4-7V (PULS. 6-200HZ)
WATER FLOW CONTROL DEVICE	<b>F1</b>	R-OR,P-OR	DC5-8V (DURING OPERATION)
		BL-OR,W-OR	
		R-P,BL-W	40-60Ω
		BR-GY	BELOW DC1V(FULL OPEN, FULL CLOSE LIMITER ON) DC4-6V(LIMITER OFF)
COMBUSTION FAN	<b>D1</b>	R-BK (GND)	DC7-48V
		Y-BK (GND)	DC11-14V
		W-BK (GND)	DC2-14V (PULS. OVER 20HZ=300RPM)

# MAINTENANCE

The appliance must be inspected, repaired and maintained by a licensed professional. The licensed professional must verify proper operation after servicing. Servicing has to be carried out annually to maintain any warranty.

For more detailed instructions on maintenance contact Rinnai or your supplier.

## Cleaning

It is imperative that control compartments, burners, and circulating air passageways of the appliance be kept clean. Clean as follows:

1. Turn off and disconnect electrical power. Allow to cool.
2. Remove the front panel by removing 4 screws.
3. Use pressurized air to remove dust from the main burner, heat exchanger, and fan blades. Do not use a wet cloth or spray cleaners on the burner. Do not use volatile substances such as benzene and thinners. They may ignite or fade the paint.
4. Use soft dry cloth to wipe cabinet.
5. When opening the combustion chamber for cleaning, the gasket needs to be renewed.
6. Complete the service log on page 39 on completion and ensure the correct Gas Safety Paperwork has been completed with a copy left with the customer. Please advise the customer to keep **ALL** records of servicing as this will be required should a warranty request be made.

## Vent System

The vent system should be inspected for blockages or damage.

## Motors

Motors are permanently lubricated and do not need periodic lubrication. However you must keep fan and motor free of dust and dirt by cleaning.

## Temperature Controller

Use a soft damp cloth to clean the temperature controller. Do not use solvents.

## Snow Accumulation

Keep the area around flue terminal free of snow and ice. The appliance will not function properly if the intake air or exhaust is impeded (blocked or partially blocked) by obstructions.

## Clean the water filter

Clean the inlet water filter by closing the cold and hot water inlet isolation (shut-off) valves. Put a bucket under the filter at the bottom of the water heater to catch any water that is contained inside the unit. Unscrew the water filter. Rinse the filter to remove any debris. Install the filter and open the isolation valves.

## Visual Inspection of Flame

Verify proper operation after servicing.

The burner must flame evenly over the entire surface when operating correctly. The flame must burn with a clear, blue, stable flame. See the parts breakdown of the burner for the location of the view ports. The flame pattern should be as shown in the figures a side.

## Lime / Scale Build-up

If you receive diagnostic code "LC#" (LC1, LC2,...), refer to the procedure, Flushing the Heat Exchanger. Refer to the section on Water Quality to see if your water needs to be treated or conditioned. (When checking maintenance code history, "00" is substituted for "LC#".)

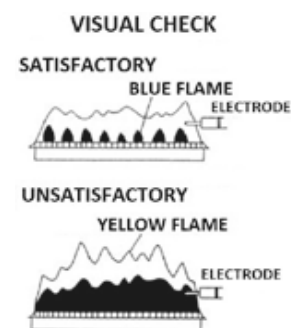

## SERVICE RECORD

It is recommended that your heating system is serviced regularly and that the appropriate Service Interval Record is completed.

### Service Provider

Before completing the appropriate Service Interval Record below, please ensure you have carried out the service as described in the manufacturer's instructions. Always use the manufacturer's specified spare part when replacing controls.

<b>SERVICE 01</b>	Date:	<b>SERVICE 02</b>	Date:
Engineer name:		Engineer name:	
Company name:		Company name:	
Telephone No:		Telephone No:	
Operative ID No:		Operative ID No:	
Comments:		Comments:	
Signature		Signature	
<b>SERVICE 03</b>	Date:	<b>SERVICE 04</b>	Date:
Engineer name:		Engineer name:	
Company name:		Company name:	
Telephone No:		Telephone No:	
Operative ID No:		Operative ID No:	
Comments:		Comments:	
Signature		Signature	
<b>SERVICE 05</b>	Date:	<b>SERVICE 06</b>	Date:
Engineer name:		Engineer name:	
Company name:		Company name:	
Telephone No:		Telephone No:	
Operative ID No:		Operative ID No:	
Comments:		Comments:	
Signature		Signature	
<b>SERVICE 07</b>	Date:	<b>SERVICE 08</b>	Date:
Engineer name:		Engineer name:	
Company name:		Company name:	
Telephone No:		Telephone No:	
Operative ID No:		Operative ID No:	
Comments:		Comments:	
Signature		Signature	
<b>SERVICE 09</b>	Date:	<b>SERVICE 10</b>	Date:
Engineer name:		Engineer name:	
Company name:		Company name:	
Telephone No:		Telephone No:	
Operative ID No:		Operative ID No:	
Comments:		Comments:	
Signature		Signature	

## Flushing the Heat Exchanger

An LC0~LC9 or "00" diagnostic code indicates the unit is beginning to lime up and must be flushed. Failure to flush the appliance will cause damage to the heat exchanger. Damage caused by lime build-up is not covered by the unit's warranty. Rinnai strongly recommends installation of isolation valves to allow for flushing of the heat exchanger.

### Flushing the heat exchanger procedure:

1. Disconnect electrical power to the water heater.
2. Close the shut off valves on both the hot water and cold water lines (V3 and V4).
3. Connect pump outlet hose (H1) to the cold water line at service valve (V2).
4. Connect drain hose (H3) to service valve (V1).
5. Pour chemical product used to flush heat exchanger into water (acid 8-10% of water content).
6. Place the drain hose (H3) and the hose (H2) to the pump inlet into the cleaning solution.
7. Open both service valves (V1 and V2) on the hot water and cold water lines.
8. Operate the pump and allow circulation through the water heater for at least 1 hour at a rate of 15 litres per minute.
9. Turn off the pump.
10. Rinse the chemical/water from the water heater as follows:
  - a. Remove the free end of the drain hose (H3) from the pail. Place in sink or outside to drain.
  - b. Close service valve, (V2), and open shut off valve, (V4). Do not open shut off valve, (V3).
  - c Allow water to flow through the water heater for 5 minutes.
  - d Close shut off valve (V4). When unit has finished draining remove the in-line filter at the cold water inlet and clean out any residue. Place filter back into unit and open valve (V4).
  - e Close service valve, (V1), and open shut off valve, (V3).
11. Disconnect all hose.
12. Restore electrical power to the water heater.

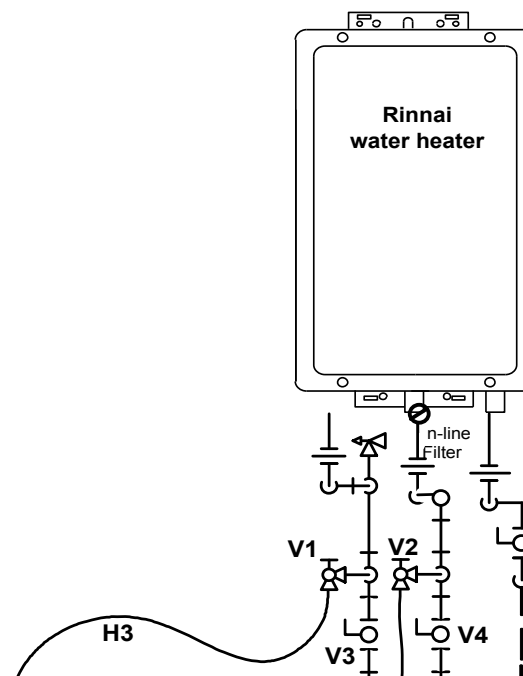
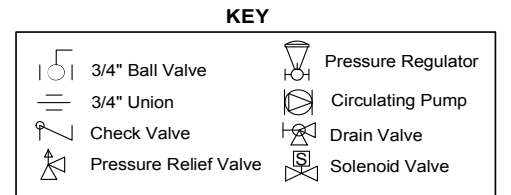

### Manual Draining of the Water Heater

If the water heater is not going to be used during a period of possible freezing weather, it is recommended that the water inside the water heater be drained.

To manually drain the water:

1. Shut off cold water supply and gas supply.
2. Turn off the temperature controller.
3. Disconnect the power to the water heater.
4. Place a container to catch the water. Open hot water tap or open hot water drain plug at the hot water outlet.
5. Remove water filter to drain the cold water.

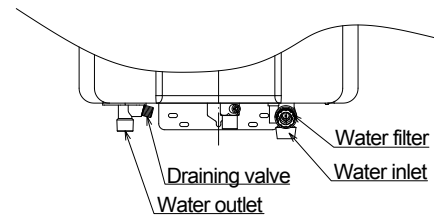

To resume normal operation:

1. Confirm that all water drain plugs are removed, that the gas supply is turned off, and that all taps are closed.
2. Screw in the water filter and the water drain plug in the hot water connections.
3. Open the cold water supply.
4. Open a tap and confirm that water flows, and then close.
5. Turn on the power.
6. After confirming that the temperature controller is off, turn on the gas supply.
7. Turn on the temperature controller.

### Running a low volume of water through the water heater to prevent freezing

If the temperature exceeds the ability of the water heater to freeze protect itself, or if power is lost, the following steps may prevent the water heater and external piping from freezing.

- Turn the water heater off.
- Close the gas supply valve.
- Turn on a hot water tap to flow water about 0.4 l/min or where the stream is about 5 mm thick.

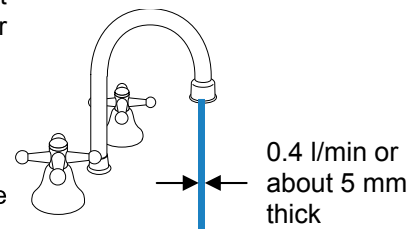

### When the water heater or external piping has frozen

1. Do not operate the water heater if it or the external piping is frozen.
2. Close the gas and water valves and turn off the power.
3. Wait until the water thaws. Check by opening the water supply valve.
4. Check the water heater and the piping for leaks.

### Coastal installations

Installations located in or near coastal areas may require additional maintenance due to corrosive airborne ocean salt.

## Technical Data

Model	11i / REU-A1111FFU-E(UK)		Unit
Installation	Indoor / Outdoor: in partially protected area		
G20 Nat Gas min gas pressure	1.83		mbar
G20 Nat Gas max gas pressure	4.97		mbar
G230 Air/Propane min gas pressure	2.15		mbar
G230 Air/Propane max gas pressure	6.22		mbar
G30 Butane min gas pressure	2.43		mbar
G30 Butane max gas pressure	6.65		mbar
G31 Propane min gas pressure	2.43		mbar
G31 Propane max gas pressure	7.53		mbar
Flue system	Forced flue, room sealed		-
Temperature range with water controller	37-46, 48, 50, 55, 60, 65		°C
Temperature range with push buttons	40, 42, 50, 55, 60, 65		°C
Ignition	Direct electronic ignition		-
<u>Gas consumption &amp; capacities min operation</u>	(Hi = net calorific value - Hs = gross calorific value)		
G20 Nat Gas: Input Qm: Hi/Hs   Output Pm	4.10/4.53   3.56		kW
G20 Nat Gas flow normal operating conditions Vm	0.43		m <sup>3</sup> /h
G230 Air/Propane Input Qm: Hi/Hs   Output Pm	4.10/4.53   3.56		kW
G230 Air/Propane flow normal operating conditions Vm	0.35		m <sup>3</sup> /h
G30 Input Qm: Hi/Hs   Output Pm	4.10/4.53   3.56		kW
G30 flow normal operating conditions Mm	0.33		kg/h
G31 Input Qm: Hi/Hs   Output Pm	4.10/4.53   3.56		kW
G31 flow normal operating conditions Mm	0.33		kg/h
<u>Gas consumption &amp; capacities nominal operation</u>	(Hi = net calorific value - Hs = gross calorific value)		
G20 Nat Gas: Input Qn: Hi/Hs   Output Pn	21.30/23.70   18.90		kW
G20 Nat Gas flow ref. conditions Vr	2.25		m <sup>3</sup> /h
G230 Air/Propane: Input Qn: Hi/Hs   Output Pn	21.80/23.70   18.90		kW
G230 Air/Propane flow ref. conditions Vr	1.79		m <sup>3</sup> /h
G30 Input Qn: Hi/Hs   Output Pn	25.10/27.20   21.80		kW
G30 flow normal operating conditions Mn	1.99		kg/h
G31 Input Qn: Hi/Hs   Output Pn	21.80/23.70   18.90		kW
G31 flow normal operating conditions Mn	1.69		kg/h
Country of destination	Refer to data-plate		-
Gas category and pressure	II2H3P, II2H3B/P, II2HM3B/P G20-20mbar, G230-20mbar, G31-37mbar, G30-30mbar		-
Type	C13, C33, C53, C63, C93, C(10)3		-
Max water flow rate	11		l/min
Min operation flow rate	ON=2 / OFF= 1		l/min
Min operating water pressure (Pmin)	0.10		bar
Water pressure (@nom/max flow rate - max) - (Pw)	1.00/1.40 - 8.30		bar
Power supply	230V/50Hz		-
Electric consumption (remote/standby/anti-frost)	G20	36/1.5/84	W
	G30	39/1.5/84	
Noise level	56		dB (A)
Ignition safety time TSAmax	4.2		sec.
Weight	14.0		kg
IP protection	IPx4D		-
Anti-freeze temperature protection	-15 <sup>2</sup>		°C
NOx	50		mg/kWh

<sup>1</sup> minimum water flow rate may vary depending on the temperature setting and the inlet water temperature.

<sup>2</sup> when protected from direct wind exposure.

Model	17i / REU-A1720FFU-E(UK)		Unit
Installation	Indoor / Outdoor: in partially protected area		
G20 Nat Gas min gas pressure	1.92		mbar
G20 Nat Gas max gas pressure	10.85		mbar
G230 Air/Propane min gas pressure	2.15		mbar
G230 Air/Propane max gas pressure	13.55		mbar
G30 Butane min gas pressure	2.68		mbar
G30 Butane max gas pressure	13.24		mbar
G31 Propane min gas pressure	2.68		mbar
G31 Propane max gas pressure	15.95		mbar
Flue system	Forced flue, room sealed		-
Temperature range with water controller	37-46, 48, 50, 55, 60, 65		°C
Temperature range with push buttons	40, 42, 50, 55, 60, 65		°C
Ignition	Direct electronic ignition		-
<u>Gas consumption &amp; capacities min operation</u>	(Hi = net calorific value - Hs = gross calorific value)		
G20 Nat Gas: Input Qm: Hi/Hs   Output Pm	4.10/4.53   3.56		kW
G20 Nat Gas flow normal operating conditions Vm	0.43		m <sup>3</sup> /h
G230 Air/Propane Input Qm: Hi/Hs   Output Pm	4.10/4.53   3.56		kW
G230 Air/Propane flow normal operating conditions Vm	0.35		m <sup>3</sup> /h
G30 Input Qm: Hi/Hs   Output Pm	4.10/4.53   3.56		kW
G30 flow normal operating conditions Mm	0.33		kg/h
G31 Input Qm: Hi/Hs   Output Pm	4.10/4.53   3.56		kW
G31 flow normal operating conditions Mm	0.33		kg/h
<u>Gas consumption &amp; capacities nominal operation</u>	(Hi = net calorific value - Hs = gross calorific value)		
G20 Nat Gas: Input Qn: Hi/Hs   Output Pn	32.40/36.00   28.40		kW
G20 Nat Gas flow ref. conditions Vr	3.43		m <sup>3</sup> /h
G230 Air/Propane: Input Qn: Hi/Hs   Output Pn	33.10/36.00   28.40		kW
G230 Air/Propane flow ref. conditions Vr	2.72		m <sup>3</sup> /h
G30 Input Qn: Hi/Hs   Output Pn	33.20/36.00   28.40		kW
G30 flow normal operating conditions Mn	2.63		kg/h
G31 Input Qn: Hi/Hs   Output Pn	33.10/36.00   28.40		kW
G31 flow normal operating conditions Mn	2.58		kg/h
Country of destination	Refer to data-plate		-
Gas category and pressure	II2H3P, II2H3B/P, II2HM3B/P G20-20mbar, G230-20mbar, G31-37mbar, G30-30mbar		-
Type	C13, C33, C53, C63, C93, C(10)3		-
Max water flow rate	20		l/min
Min operation flow rate	ON=2 / OFF= 1		l/min
Min operating water pressure (Pmin)	0.10		bar
Water pressure (@nom/max flow rate - max) - (Pw)	1.00/1.40 - 8.30		bar
Power supply	230V/50Hz		-
Electric consumption (remote/standby/anti-frost)	G20	84/1.5/116	W
	G30	69/1.5/116	
Noise level	56		dB (A)
Ignition safety time TSAmx	4.2		sec.
Weight	14.5		kg
IP protection	IPx4D		-
Anti-freeze temperature protection	-15 <sup>2</sup>		°C
NOx	50		mg/kWh

<sup>1</sup> minimum water flow rate may vary depending on the temperature setting and the inlet water temperature.

<sup>2</sup> when protected from direct wind exposure

Model	17 E / REU-A1720W-E(UK)		Unit
Installation	Outdoor		
G20 Nat Gas min gas pressure	1.58		mbar
G20 Nat Gas max gas pressure	9.0		mbar
G230 Air/Propane min gas pressure	1.89		mbar
G230 Air/Propane max gas pressure	11.57		mbar
G30 Butane min gas pressure	2.29		mbar
G30 Butane max gas pressure	11.6		mbar
G31 Propane min gas pressure	2.29		mbar
G31 Propane max gas pressure	15.1		mbar
Flue system	Forced flue, direct		-
Temperature range with water controller	37-46, 48, 50, 55, 60, 65		°C
Temperature range with push buttons	40, 42, 50, 55, 60, 65		°C
Ignition	Direct electronic ignition		-
<u>Gas consumption &amp; capacities min operation</u>	(Hi = net calorific value - Hs = gross calorific value)		
G20 Nat Gas: Input Qm: Hi/Hs   Output Pm	4.10/4.53   3.56		kW
G20 Nat Gas flow normal operating conditions Vm	0.43		m³/h
G230 Air/Propane Input Qm: Hi/Hs   Output Pm	4.10/4.53   3.56		kW
G230 Air/Propane flow normal operating conditions Vm	0.35		m³/h
G30 Input Qm: Hi/Hs   Output Pm	4.10/4.53   3.56		kW
G30 flow normal operating conditions Mm	0.33		kg/h
G31 Input Qm: Hi/Hs   Output Pm	4.10/4.53   3.56		kW
G31 flow normal operating conditions Mm	0.33		kg/h
<u>Gas consumption &amp; capacities nominal operation</u>	(Hi = net calorific value - Hs = gross calorific value)		
G20 Nat Gas: Input Qn: Hi/Hs   Output Pn	32.40/36.00   28.40		kW
G20 Nat Gas flow ref. conditions Vr	3.43		m³/h
G230 Air/Propane: Input Qn: Hi/Hs   Output Pn	33.10/36.00   28.40		kW
G230 Air/Propane flow ref. conditions Vr	2.72		m³/h
G30 Input Qn: Hi/Hs   Output Pn	33.20/36.00   28.40		kW
G30 flow normal operating conditions Mn	2.63		kg/h
G31 Input Qn: Hi/Hs   Output Pn	33.10/36.00   28.40		kW
G31 flow normal operating conditions Mn	2.58		kg/h
Country of destination	Refer to data-plate		-
Gas category and pressure	II2H3P, II2H3B/P, II2HM3B/P G20-20mbar, G230-20mbar, G31-37mbar, G30-30mbar		-
Type	A3		-
Max water flow rate	20		l/min
Min operation flow rate	ON=2 / OFF= 1		l/min
Min operating water pressure (Pmin)	0.10		bar
Water pressure (@nom/max flow rate - max) - (Pw)	1.00/1.40 - 8.30		bar
Power supply	230V/50Hz		-
Electric consumption (remote/standby/antifrost)	G20	55/1.5/84	W
	G30	53/1.5/84	
Noise level	56		dB (A)
Ignition safety time TSAmax	4.2		sec.
Weight	14.5		kg
IP protection	IPx5D		-
Anti-freeze temperature protection	-20 <sup>2</sup>		°C
NOx	50		mg/kWh

<sup>1</sup> minimum water flow rate may vary depending on the temperature setting and the inlet water temperature.

<sup>2</sup> when protected from direct wind exposure



## Product Fiche

		Unit
Supplier's name	Rinnai UK	
Supplier's model	REU-A1111FFU-E(UK)	
Load profile	S	
Water heating energy efficiency class	A+	
Water heating energy efficiency ( $\eta_{wh}$ )	69.2	%
Annual electricity consumption (AEC)	7	kWh/annum
Annual fuel consumption (AFC) - (Hs)	2	GJ/annum
Temperature setting <sup>1</sup>	55	°C
Indoor sound power level (LWA)	59	db

Values tested with appliance set @60°C - Gas: G20mbar - High calorific value (Hs) - According to Reg. UE 812/2013.

<sup>1</sup> 40°C with water control connected.

		Unit
Supplier's name	Rinnai UK	
Supplier's model	REU-A1720FFU-E(UK)	
Load profile	L	
Water heating energy efficiency class	A	
Water heating energy efficiency ( $\eta_{wh}$ )	79.1	%
Annual electricity consumption (AEC)	14	kWh/annum
Annual fuel consumption (AFC) - (Hs)	11	GJ/annum
Temperature setting <sup>1</sup>	55	°C
Indoor sound power level (LWA)	59	db

Values tested with appliance set @60°C - Gas: G20mbar - High calorific value (Hs) - According to Reg. UE 812/2013.

<sup>1</sup> 40°C with water control connected.

		Unit
Supplier's name	Rinnai UK	
Supplier's model	REU-A1720W-E(UK)	
Load profile	XL	
Water heating energy efficiency class	A	
Water heating energy efficiency ( $\eta_{wh}$ )	81.5	%
Annual electricity consumption (AEC)	19	kWh/annum
Annual fuel consumption (AFC) - (Hs)	18	GJ/annum
Temperature setting <sup>1</sup>	55	°C
Indoor sound power level (LWA)	—	db

CE  
0461

Technigas

**MODULE B : EU TYPE-EXAMINATION — PRODUCTION TYPE**

according to ANNEX III point 1 of

REGULATION (EU) 2016/426 OF THE EUROPEAN PARLIAMENT

<i>Certificate number</i>	E6361/5399- Rev. 1	<i>Date of issue</i>	03/04/2018
<i>ID number</i>	0461BQ0836	<i>Revision date</i>	12/10/2018
		<i>Validity date</i>	02/04/2028

*Manufacturer* RINNAI Corporation  
Fukuzumi-Cho 2-26  
JP- Nakagawa-Ku / Nagoya

*Marketed* RINNAI Corporation  
Fukuzumi-Cho 2-26  
JP- Nakagawa-Ku / Nagoya

*Trade mark* RINNAI

*Model* (\*) REU-1116FFU-E // REU-1420FFU-E // REU-1720FFU-E  
(\*\*) REU-A1111FFU-E // REU-A1420FFU-E // REU-A1720FFU-E

*Kind of Product* Gas-fired instantaneous water heaters for the production of domestic hot water

*Appliance type* (\*) C13/ C33/ C53  
(\*\*)C13/ C33/ C53/ C63/ C93/ C(10)3  
(Attention : Some types are not used or are forbidden in certain countries. See CEN/TR 1749 and regulations in force in each country).

Countries of destination, appliance categories :

AL – AT – BE – BG – CH – CY – CZ – DE – DK – EE – ES – FI – FR – GB – GR – HU – HR – IE – IS – IT – LT – LU – LV – MK – MT – NL – NO – PL – PT – RO – SE – SI – SK – TR

(\*) II<sub>2H3P</sub> // II<sub>2H3B/P</sub> // II<sub>2HM3B/P</sub> // I<sub>2E</sub> // I<sub>2E(S)</sub> // I<sub>2Esi</sub> // I<sub>2H</sub> // I<sub>3P</sub> // I<sub>3B/P</sub> // I<sub>3R</sub>  
(\*\*)II<sub>2H3P</sub> // II<sub>2H3B/P</sub> // II<sub>2HM3B/P</sub> // I<sub>2H</sub> // I<sub>3P</sub> // I<sub>3B/P</sub> // I<sub>3R</sub>

G20-20 mbar // G20/G25-20/25 mbar //G30-30 mbar // G31-30 mbar // G31-37 mbar // G230-20mbar

This document cancels and replaces the previous one of :03/04/2018



Bernard Nève  
Director

TGF-08-14\_v04  
24-07-2017

TECHNIGAS  
Chaussée de Vilvorde, 156  
BE-1120 Brussels  
Phone +32 (0)2 264 03 60  
Fax +32 (0)2 268 89 58  
[www.technigas.be](http://www.technigas.be)



199-PROD

**This page is intentionally left blank**

# Rinnai UK Ltd

9 Christleton Court  
Manor Park  
Runcorn  
WA7 1ST

[www.rinnaiuk.com](http://www.rinnaiuk.com)  
01928 531 870



SU170-910×01 SX

V.3 - 6/14/19 - *This manual replaces any edition previously published.*